

Raychem

TraceTek TTDM Series Leak Detection and Location Modules Replacement Parts

TraceTek TTDM Replacement Parts

Catalog no.	Description
TTDM-4/20	TTDM 4-20 mA current transmitter board
TTDM-SI	TTDM sensor interface board
TTDM-Relay	TTDM relay
TTDM-PS1	TTDM power supply board, 115 Vac
TTDM-PS2	TTDM power supply board, 230 Vac
TTDM-PS24	TTDM power supply board, 24 Vdc
TTDM-fuse	200 mA, 250V, quick-acting microfuses for TTDM-PS (bag of 5)
TTDM-MB	TTDM motherboard
TTDM-RC1	TTDM ribbon cable, 6 inches long, with connectors installed
TTDM-UI	TTDM user interface assembly
TTDM-UI-EPROM-x	TTDM-UI EPROM replacement; upgrades UI software to version indicated by x suffix; for new features, see TTDM Software Release Bulletin H55874; instructions for replacing the EPROM are covered in a separate document (H55875) which is shipped with the EPROM.

Storage

Keep replacement parts in a dry place prior to installation to avoid possible damage to electronic components.

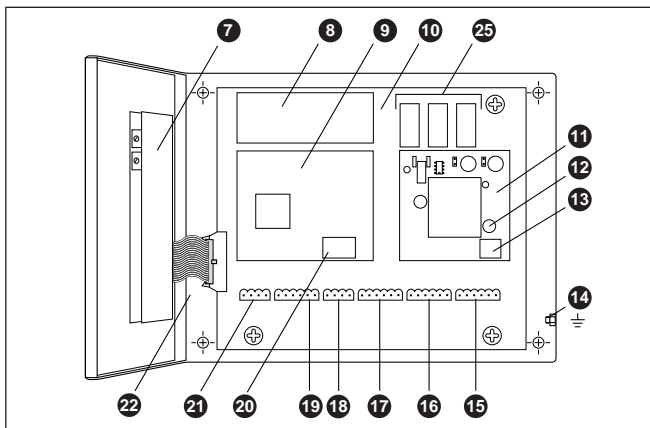

- | | |
|--|---|
| 7 User Interface board (not in TTDM-SIM) | 17 Service relay cable plug and socket (not in TTDM-SIM) |
| 8 4-20 mA board (not in TTDM-SIM) | 18 4-20 mA port plug and socket (not in TTDM-SIM) |
| 9 Sensor Interface Board | 19 RS-232/485 port plug and socket (not in TTDM-SIM) |
| 10 Motherboard | 20 Sensor Interface plug and socket |
| 11 Power Supply Board | 21 RS-485 plug and socket for SIM network (only for use in TTDM-NMM and TTDM-SIM) |
| 12 Fuse (200 mA, 250 V) | 22 Ribbon cable (not in TTDM-SIM) |
| 13 Power cable terminal block | 25 Relays |
| 14 Ground/earth stud | |
| 15 Fault relay cable plug and socket (not in TTDM-SIM) | |
| 16 Leak relay cable plug and socket (not in TTDM-SIM) | |

General Information

These instructions detail the steps to replace parts in the TraceTek TTDM series leak detection and location modules (catalog numbers TTDM, TTDM-NMM, and TTDM-SIM). The modular design of the TTDM makes it possible to replace individual boards - rather than the entire unit - if part of the module is damaged or malfunctioning. These instructions explain how to install the replacement parts detailed at left, except for the TTDM-UI-EPROM. Instructions for replacing the EPROM are covered in a separate document (H55875) which is shipped with the EPROM.

These instructions for replacing parts are complemented by instructions for installing the modules (document H55471 for the TTDM and TTDM-NMM; H56314 for the TTDM-SIM). You may obtain other Raychem literature from our Fax-on-Demand service at (800) 329-4494; a voice prompt guides you through the process.

The TTDM is an electronic unit. Its circuit boards should be replaced only by a person qualified for work on electronic instrumentation and controls.

Tools Required

- Phillips (cross-head) screwdriver (for power supply boards, motherboard, and user interface assembly)
- Small flat-head screwdriver (for power supply and other terminal blocks)
- 9/32 in. nut driver (for user interface assembly)
- 7 mm nut driver or wrench (if removing enclosure door to replace User Interface assembly)

Precautions

Important: The TTDM is an electronic unit. When replacing parts, take the following precautions to avoid damage to its electronic components:

- Handle with care, avoid mechanical damage.
- Keep the electronics dry.
- If handling circuit boards, hold them by their edges to avoid physical contact with electronic components.
- Avoid contamination with metal filings, liquids, or other foreign matter

Before disconnecting power to the TTDM and replacing parts, alert any groups that must respond to alarms signaled by the TTDM (an emergency response team, for example) that you will be working on the unit.

⚠ WARNING

SHOCK HAZARD. Disconnect power to the TTDM before opening enclosure door.

Important:

After replacing one or more parts following these instructions, test the module in accordance with the module's installation instructions (H55471 for a TTDM or TTDM-NMM, H56314 for a TTDM-SIM).

Table of Contents—instructions for replacement parts

4-20 mA current transmitter board	A
SI board	B
Relays	C
Power supply boards and fuse	D
Ribbon cable	E
Motherboard	F
User Interface assembly	G
References for other parts	H

A. Replacing the TTDM 4-20 mA Current Transmitter Board (not in TTDM-SIM)

1. Remove old 4-20 mA board from the TTDM.

Remove the 4-20 mA current transmitter board. Grasp the circuit board by its edges and pull up from the motherboard. Gently rocking the board left to right 5° to 10° may help release the connection.

2. Install the new 4-20 mA board.

Position the new 4-20 mA current transmitter board; orient the board so its markings are right side up. Before applying pressure to seat the board, take care to align the connectors along the top and bottom edges of the 4-20 mA board with their mating connectors on the motherboard.

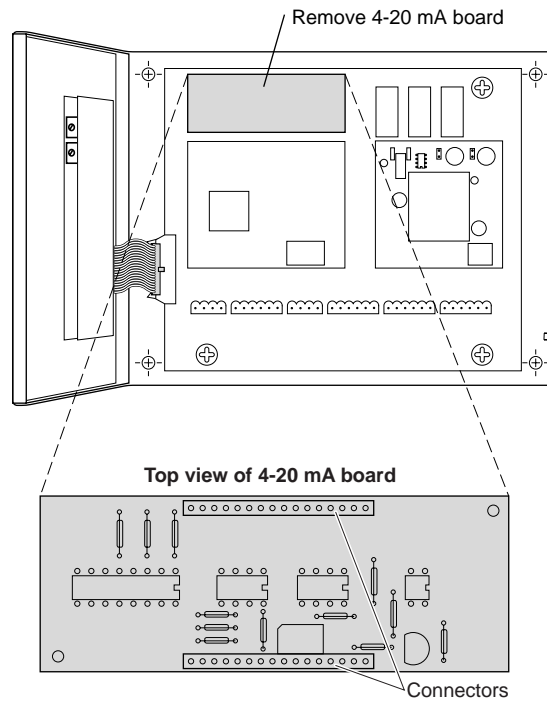

B. Replacing the TTDM SI Board

- 1. Remove Sensor Interface plug from socket on SI board.**
Pull out Sensor Interface plug (feature 20) from its socket on the old SI board.
- 2. Remove old Sensor Interface (SI) board.**
Remove old SI board. If SI board is secured with hold-down screws, remove the screws (2 places) and store them. Grasp the circuit board by its edges and pull up from the motherboard. Gently rocking the board top to bottom 5° to 10° may help release the connection.
- 3. Install new Sensor Interface (SI) board.**
Position the new Sensor Interface board; orient the board so its markings are right side up. Before applying pressure to seat the board, take care to align the connectors along the left and right edges of the SI board with their mating connectors on the motherboard. Gently rocking the board top to bottom 5° to 10° may help seat the board, which snaps into place when fully seated. If SI board was secured with hold-down screws, insert and align the screws, and use Phillips (cross-head) screwdriver to tighten them hand tight.
- 4. If TTDM-NMM or TTDM-SIM, assign SIM address to the new Sensor Interface board.**
If the module is a TTDM-NMM or TTDM-SIM (part of a TraceTek leak detection network), the new Sensor Interface board must be assigned a SIM address following the instructions on page 28 of the *TraceTek TTDM-NMM and TTDM-SIM System Operation and Maintenance Manual* (H56313), and on page 5 of the *TraceTek TTDM-SIM Installation Instructions* (H56314). Note that address 01 is the factory default of the Sensor Interface board in the TTDM-NMM, but this address must be assigned (following the procedure referenced above) when a new Sensor Interface board is installed.
- 5. Insert sensing cable plug into socket.**
Insert Sensor Interface plug into the SI socket on the new SI board.

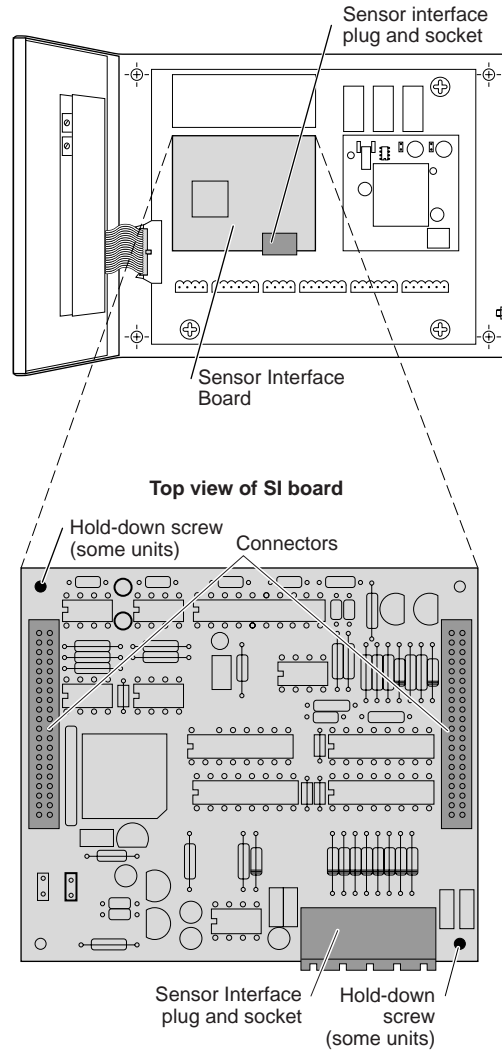

C. Replacing a TTDM Relay (not in TTDM-SIM)

1. Remove old relay.

Rotate relay hold-down spring to the side, then pull relay out of its socket in the motherboard.

2. Install new relay.

Carefully align leads from the relay with the sockets on motherboard, then insert the relay leads into motherboard. Rotate hold-down spring back into position to retain the relay in place.

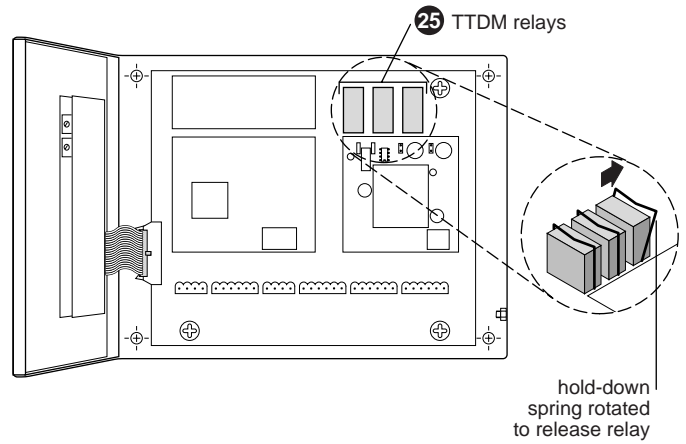

D. Replacing the TTDM Power Supply Board

⚠ WARNING: SHOCK HAZARD. Confirm power to the TTDM has been disconnected before opening enclosure door and replacing the power supply board.

1. Disconnect the power wiring.

Use a small flat-blade screwdriver to disconnect the power supply wires from the two-pin terminal block on the power supply board (feature 13).

2. Remove the hold-down screws.

Use a Phillips (cross-head) screwdriver to remove the hold-down screws at the top left and bottom right corners of the power supply board.

3. Remove the old power supply board.

Grasp the circuit board by its edges and pull up from the motherboard. Gently rocking the board top to bottom a maximum 5° to 10° may help release the connection.

4. Install new power supply board.

Position the new power supply board; terminal block on TTDM-PS1 or TTDM-PS2 should be in lower right corner. Before applying pressure to seat the board, take care to align the connectors along the left and right edges of the SI board with their mating connectors on the motherboard. Gently rocking the board top to bottom 5° to 10° may help seat the board, which snaps into place when fully seated.

Important: Confirm that the new power supply board has the correct voltage rating for the supply voltage to be used; do not exceed the maximum voltage rating of the power supply board.

5. Re-install hold-down screws.

Insert and align hold-down screws, and use Phillips (cross-head) screwdriver to fasten them hand tight.

Important: Do not over tighten, as this could damage motherboard.

6. Reconnect the power wiring.

Connect the power supply wires to the two-pin terminal block on the power supply board. Use L2 for neutral, if present.

Note: In the TTDM-PS24 board (which operates at 24 Vdc or Vac), the terminal block for the power supply wires is in the center of the board, rather than at the lower right. For DC operation, polarity does not matter.

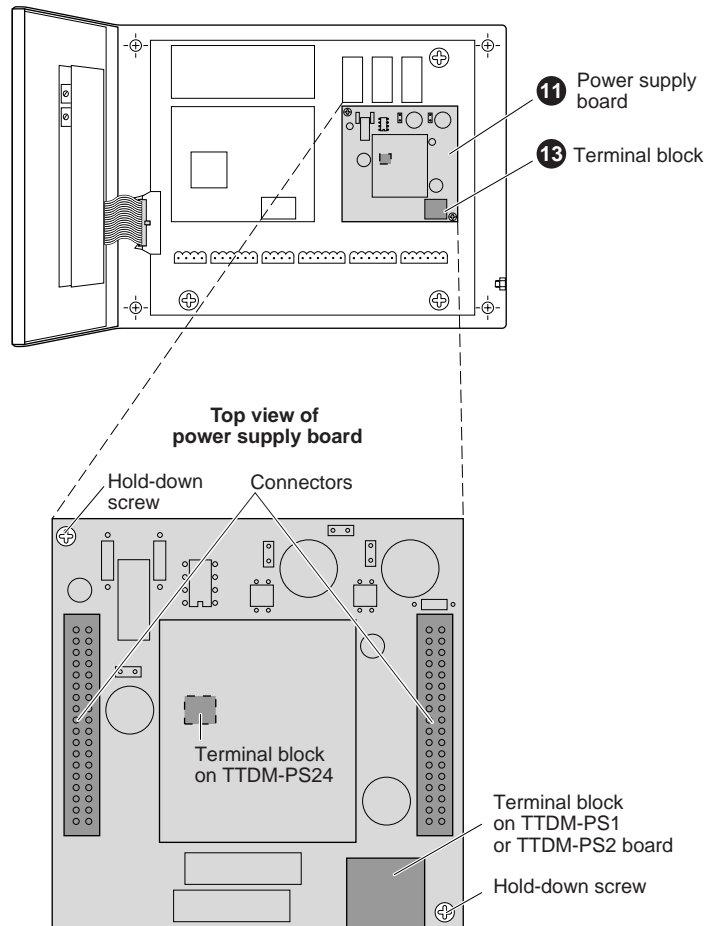

E. Replacing the TTDM Ribbon Cable (not in TTDM-SIM)

1. Disconnect ribbon cable from motherboard and user interface assembly.

Release the fastening ears of the ribbon cable connectors (as illustrated in Figure 1 at right), and pull the ribbon cable away from the motherboard and the user interface assembly.

Figure 1

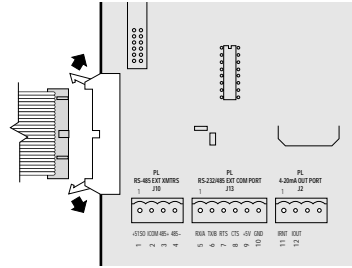

2. Connect new ribbon cable to motherboard.

Orient the new cable so the single wide key protrusion of a connector and the ribbon cable coming from that connector both face up as illustrated in Figure 2 (a connector cannot be inserted unless the key is oriented correctly; the direction of the cable from the connector can affect the stress to which the cable may be subjected). Align the ribbon cable connector and insert it into the motherboard connector (taking care not to bend any pins). Press the ribbon cable connector into the motherboard until the locking ears latch in place (as illustrated in Figure 3).

Figure 2

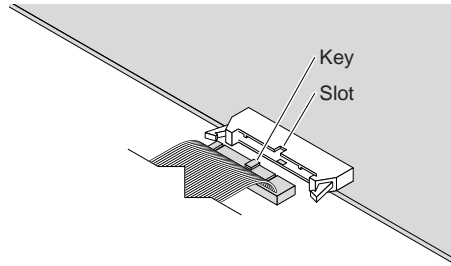

3. Connect new ribbon cable to user interface assembly.

Align the ribbon cable connector and insert it into the user interface assembly (taking care not to bend any pins). Press the ribbon cable connector into the user interface assembly until the locking ears latch in place.

Figure 3

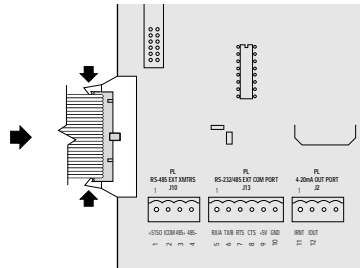

F. Replacing the TTDM Motherboard

1. Disconnect ribbon cable from old motherboard.

Release the fastening ears of the ribbon cable connector, and pull the ribbon cable from the motherboard. See Figure 1 in Section E (page 6).

2. Disconnect the power wiring.

⚠ WARNING: SHOCK HAZARD.

Use a small flat-blade screwdriver to disconnect the power supply wires from the two-pin terminal block on the power supply board (feature 13).

3. Remove plugs for external connections from sockets at bottom of motherboard and sensor interface board.

- Mark each of the plugs for external connections so you can readily plug them into the correct sockets on the new motherboard.
- Remove each of the plugs for external connections from its socket on the motherboard. The external connections available in the TTDM are listed in the table at right.

4. Remove 4-20 mA board from motherboard.

Remove 4-20 mA current transmitter board from old motherboard (see step 1, Section A) and put it out of harm's way.

5. Remove old motherboard.

Unscrew the four Phillips (cross-head) screws that hold the motherboard to the enclosure. Remove the motherboard

6. Remove daughterboards from old motherboard and install them on new motherboard.

- Remove Sensor Interface board from old motherboard and install on new motherboard following instructions in Section B (page 3).
- Remove relays from old motherboard and install on new motherboard following instructions in Section C (page 4).
- Remove power supply board from old motherboard and install on new motherboard following instructions in Section D (page 5).

7. Install new motherboard.

Position the new motherboard, and fasten it in place with the Phillips (cross-head) screws.

8. Install 4-20 mA board on new motherboard.

Install 4-20 mA current transmitter board on new motherboard; see step 2 of Section A (page 2).

9. Insert plugs for external connections into sockets on new motherboard.

Insert the plugs for the external connections into their corresponding sockets on the new motherboard.

10. Re-connect the power supply wires.

Re-connect the power supply wires to the two-pin terminal block on the power supply board. Use L2 for neutral, if present (however, if using TTDM-24 at 24 Vdc, polarity does not matter).

11. Connect ribbon cable to new motherboard.

Reconnect the ribbon cable (taking care not to bend any pins in the connection). Press the connector into the motherboard until the locking ears latch in place. See Figure 2 in Section E (page 6).

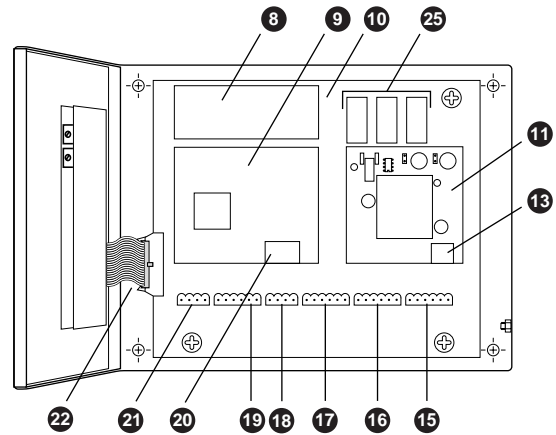

Feature no.	Description of external connection
15	Fault relay
16	Leak relay
17	Service Required relay
18	4-20 mA port
19	RS-232/485 external communications serial port
20	Sensor Interface
21	Leak detection network (TTDM-NMM and TTDM-SIM only)

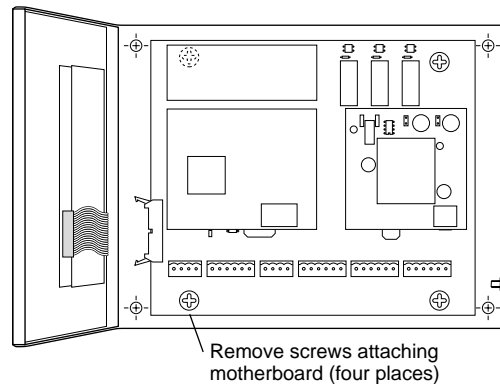

G. Replacing the TTDM User Interface Assembly (not in TTDM-SIM)

Note: If the old user interface is functioning, it is recommended that the events history be printed out or downloaded through the serial port (or recorded in some other manner) before the User Interface Assembly is replaced. All user defined settings should also be recorded in some manner, as a new User Interface Assembly comes with the factory defaults.

If the user interface is not functioning, save the old user interface assembly and return it to Raychem for diagnostic testing and/or download of events and settings.

1. Disconnect ribbon cable.

Release the fastening ears of the ribbon cable connectors, and pull the ribbon cable away from the user interface assembly. See Figure 1.

2. Place enclosure or enclosure door on horizontal surface.

It is much easier to replace the user interface assembly if the unit is on a horizontal surface. The easiest approach may be to remove the TTDM enclosure from the location where it is mounted, and place the complete unit on the horizontal surface; for guidance on how to install—or remove—the TTDM module, see the *Installation Instructions for TTDM Alarm and Locating Module, H55471*.

If it is not practical to move the entire TTDM unit, the door can be removed from the enclosure. To remove the door of the enclosure,

- Disconnect the ground/earth wire from the User Interface assembly to the ground/earth stud inside the enclosure; use 9/32 nut driver to remove locknut that holds it in place.
- Use a 7 mm nut driver or wrench to remove the nuts which hold the hinge (the hinge nuts are inside the enclosure, as shown in Figure 2).
- After removing the nuts and nylon sealing washers, put them in a safe place while you are replacing the user interface assembly.

3. Remove old user interface assembly.

- Use 9/32 inch nut driver to remove the 8 nuts which secure the assembly to the enclosure door (see Figure 3).
- Remove the 8 flat washers and keep them with the nuts.
- Lift the user interface assembly off the enclosure door. Take care not to damage the sealing gasket when doing so; pull the assembly away gently, and then handle the gaskets with care.

4. Position the gaskets on the inside of the panel door.

- Place the two spacer gaskets (of fiber construction resembling paper) in position around the eight mounting studs (see Figure 4).
- Place the foam sealing gasket in position inside the eight mounting studs.

Figure 1

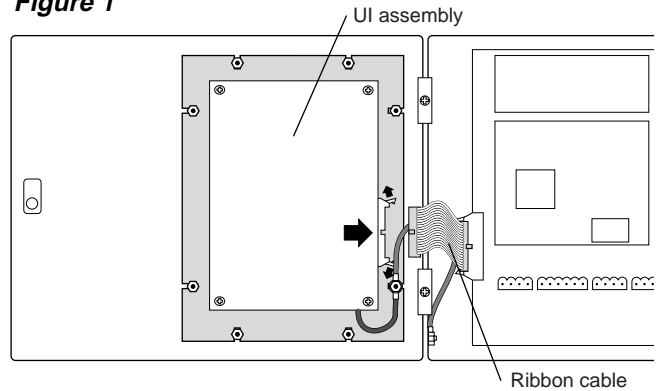

Figure 2

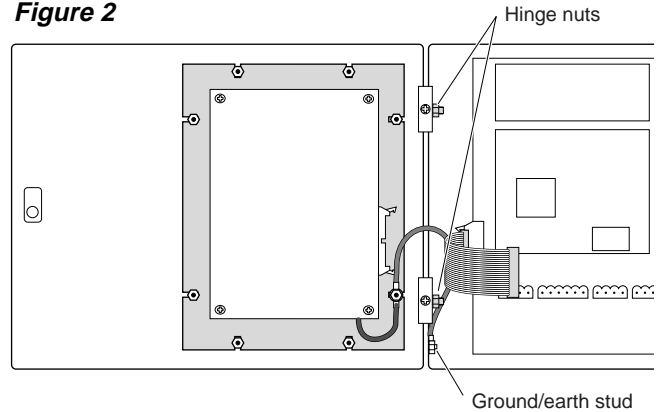

Figure 3

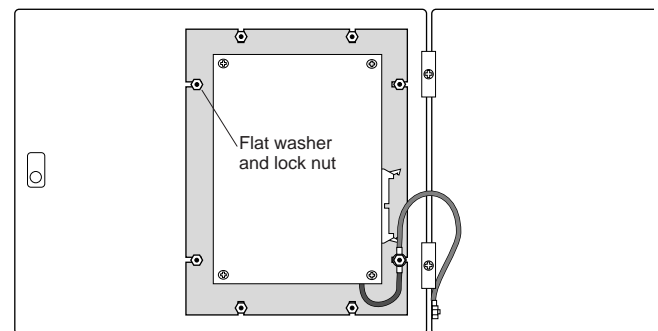
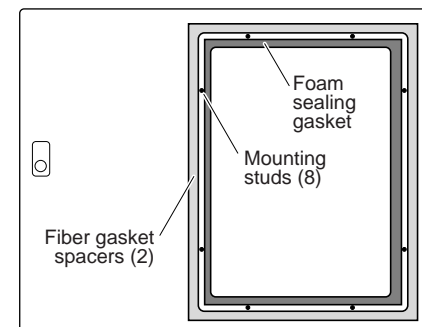

Figure 4



5. Mount the User Interface Assembly inside enclosure door.

- Place the TTDM User Interface Assembly in position; the eight mounting studs go through the eight slots on the UI Assembly mounting plate.
- Place flat washers (8) on mounting studs.
- Position the ring tongue terminal of the UI Interface ground (earth) wire and the wire to the enclosure ground/earth over a mounting screw as illustrated.
- Place a 8-32 locknut (with attached star lock washer) on each of the eight mounting screws; fasten only hand tight.
- Look at the front of the panel, and align the User Interface Assembly so it is level (loosen nuts if necessary to reposition the UI Assembly). For the most attractive appearance, position the sealing gasket so it is not visible inside the display opening; the gasket can be tamped into place with a matchbook or something similar, but take care not to damage it.
- Tighten the nuts after the display and gasket are properly positioned. Use 9/32 inch nut driver to snug the nuts; do so by hand; do not overtighten and risk damage to hardware.

6. Reconnect the ribbon cable.

Align the ribbon cable connector and insert it into the new user interface assembly (taking care not to bend any pins). Press the ribbon cable connector into the user interface assembly until the locking ears latch in place.

7. Remount enclosure or enclosure door.

Remount the TTDM enclosure or the enclosure door (remounting or reassembling, based on action taken at step 2). **Important:** If enclosure door was removed, be sure to reconnect ground/earth wire from User Interface assembly to ground/earth stud inside enclosure.

Figure 5

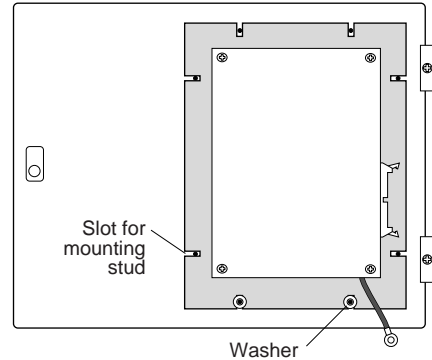
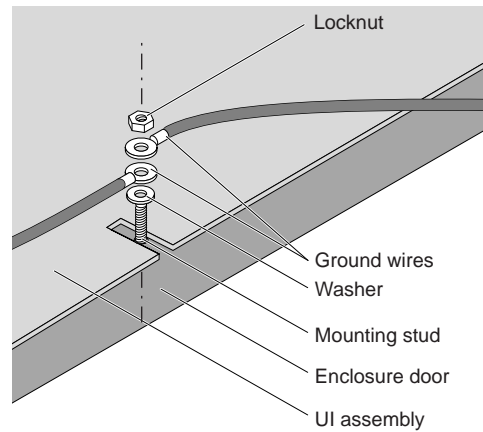

Figure 6



H. References for Replacing other TTDM Parts

TTDM-UI-EPROM-x

TTDM User Interface software can be upgraded by replacing the EPROM on the user interface assembly. The *TTDM Software Release Bulletin* (Raychem document H55874) summarizes the features provided by new software versions. Software upgrades are made available in the form of an EPROM, together with the instructions for replacing the EPROM (Raychem document H55875).

Terminal block connections

The *TraceTek TTDM Leak Detection and Location Module Installation Instructions* (Raychem document H55471) describes how to connect power wiring, relay wiring, and sensing cable to the TTDM unit. The *TTDM Installation and Operation Manual* (Raychem document H55472) provides connection details for the 4-20 mA port and the RS-232/485 serial port.

www.raychem.com
cheminfo@raychem.com

Belgium
NV Raychem SA
Diestsesteenweg 692
3010 Kessel-Lo
Tel (32) 16/351-800
Fax (32) 16/351-797

Korea
Raychem Korea Limited
831-45 Yeuksam-Dong
Kangnam-Ku
Seoul 135-080
Tel (82) 3468-1300
Fax (82) 2/558-5765

United Kingdom
Raychem Ltd.
Faraday Road
Dorcan, Wiltshire SN3 5HH
Tel (44) 1793/572-663
Fax (44) 1793/572-629

United States
Raychem Corporation
300 Constitution Drive
Menlo Park, CA 94025-1164
Tel (800) 553-1737
Fax (650) 361-5073