

***Raychem***

# **RaySol System**

**DESIGN GUIDE**

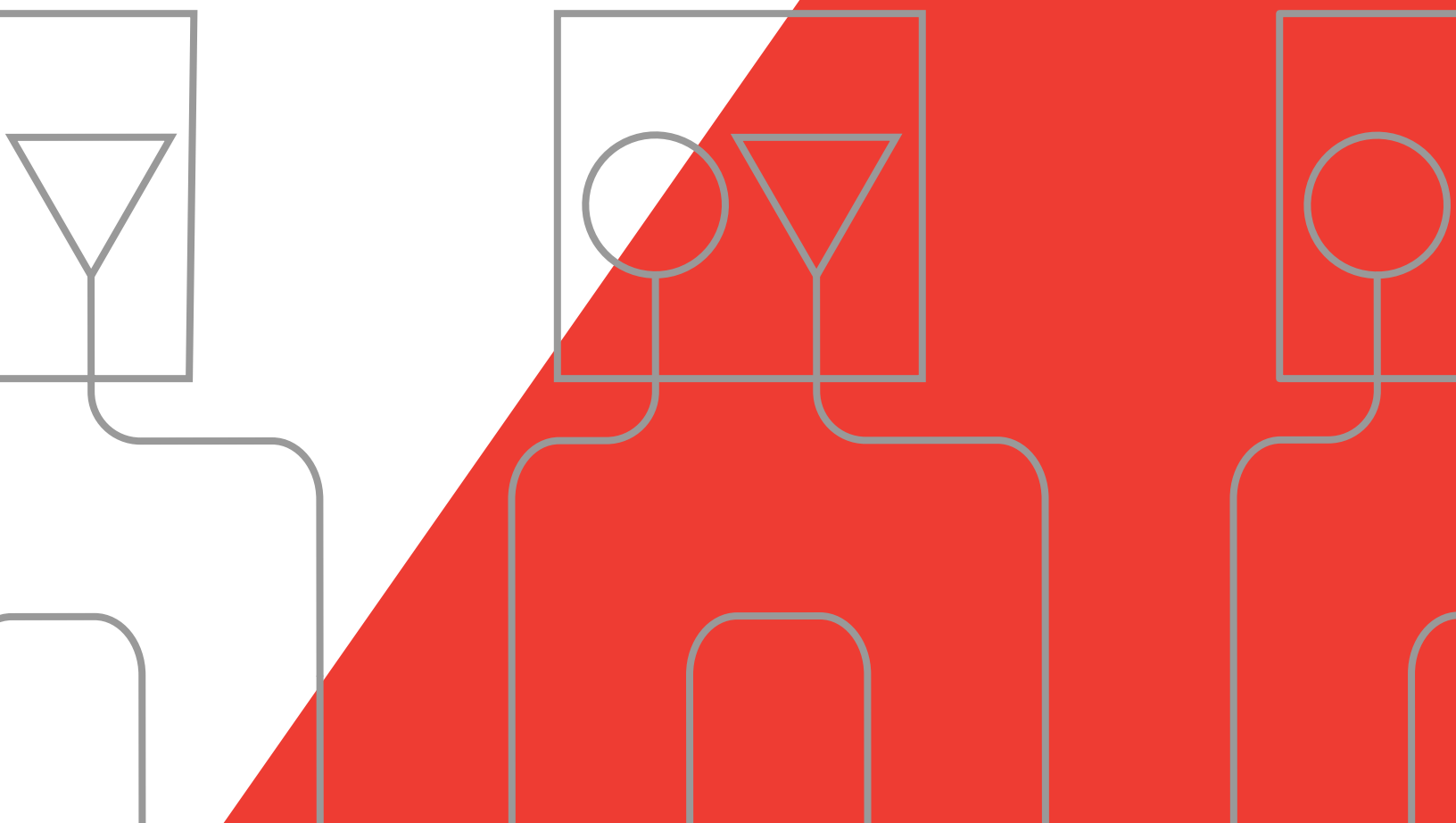



## Table Of Contents

<b>1. Overview</b>	1.1 Introduction	1
	1.2 How to Use This Guide	1
	1.3 System Description	2
	1.4 Codes and Approvals	2
	1.5 Warranty	2
<b>2. Heat-Loss Replacement</b>	2.1 Application	3
	2.2 Heating Cable and Components	3
	2.3 Design Assumptions	3
	2.4 Design: Determining Heating Cable Spacing	4
	2.5 Layout: Laying Out Heating Cable and Components	5
	2.6 Electrical Design: Selecting and Sizing Electrical Parameters	7
	2.7 Example	8
<b>3. Concrete Floor Warming</b>	3.1 Application	9
	3.2 Heating Cable and Components	9
	3.3 Design Assumptions	9
	3.4 Design: Determining Heating Cable Spacing	10
	3.5 Layout: Laying Out Heating Cable and Components	11
	3.6 Electrical Design: Selecting and Sizing Electrical Parameters	13
	3.7 Example	15
<b>4. Tile and Marble Floor Warming</b>	4.1 Application	17
	4.2 Heating Cable and Components	17
	4.3 Design Assumptions	18
	4.4 Design: Determining Heating Cable Spacing	18
	4.5 Layout: Laying Out Heating Cable and Components	19
	4.6 Electrical Design: Selecting and Sizing Electrical Parameters	21
	4.7 Example	22
<b>5. Freezer Frost Heave Prevention</b>	5.1 Application	23
	5.2 Heating Cable and Components	24
	5.3 Design Assumptions	24
	5.4 Design: Determining Heating Cable Spacing	24
	5.5 Layout: Laying Out Heating Cable and Components	25
	5.6 Electrical Design: Selecting and Sizing Electrical Parameters	28
	5.7 Example	29
<b>6. Condensed Specification Guide</b>	6.1 Floor Warming and Heat Loss Replacement	31
	6.2 Tile and Marble Floor Warming	32
	6.3 Freezer Frost Heave Prevention	33
<b>7. Appendix A</b>	7.1 Warranty; Suitability	35



# 1. Overview

## 1.1 Introduction

The RaySol system is designed for four distinct types of applications:

- Heat-loss replacement for concrete floors
- Concrete floor warming
- Tile and marble floor warming
- Freezer frost heave prevention

This design guide presents Raychem's recommendations for designing a RaySol system for each of these applications. Following the recommendations will result in a reliable, energy-efficient system.

For information regarding other heating and heat-tracing applications, contact your Raychem representative.



## 1.2 How to Use This Guide

Table 1.1 on the next page summarizes each type of application and indicates which section in this guide contains the design recommendations for that application.

When using the *RaySol System Design Guide*, follow these steps:

- Step 1. Define the application.
- Step 2. Turn to the appropriate section for that application (refer to Table 1.1 on the next page).
- Step 3. Select the spacing of the RaySol heating cable.
- Step 4. Determine the heating cable and component layout.
- Step 5. Design the electrical system.

If, after reading this design guide, you still have questions concerning the design of a RaySol system, contact your Raychem representative. For instructions on installing a RaySol system, be sure to read and follow the RaySol Installation Manual (H54693).

 **WARNING: RaySol heating cables and associated system components are electrical devices that must be designed and installed properly to ensure proper operation and to prevent shock or fire. Follow all design, installation, assembly, and test instructions. Warnings are highlighted with  in this design guide.**

# 1. Overview

**Table 1.1. Application Summary and Section Selection**

Application	Heat-loss replacement for concrete floors	Concrete floor warming	Tile and marble floor warming	Freezer frost heave prevention
<b>Uses</b>	Replace heat in concrete floors built over: <ul style="list-style-type: none"> <li>• garages</li> <li>• loading docks</li> <li>• arcades</li> <li>• other cold spaces</li> </ul>	Warm concrete floors in: <ul style="list-style-type: none"> <li>• bathrooms</li> <li>• foyers</li> <li>• schools</li> <li>• gymnasiums</li> </ul>	Warm tile and marble floors in: <ul style="list-style-type: none"> <li>• bathrooms</li> <li>• foyers</li> </ul>	Prevent heaving in soils under: <ul style="list-style-type: none"> <li>• freezers</li> <li>• refrigerated warehouses</li> <li>• cold rooms</li> </ul>
<b>Installation</b>	Placed in conduit embedded in concrete floors, or attached to the bottom of concrete floors	Placed in conduit embedded in concrete floors, or attached to the bottom of concrete floors	Embedded in mortar under tile or marble	Placed in conduit buried in soil or in the subflooring under the freezer floor
<b>Floor design temperature</b>	70°F (min.)	80°F (min.)	80°F (min.)	N/A
<b>Typical heating cable spacing</b>	18" to 42"	5" to 12"	7" to 9"	30" to 96"
<b>Design guide section</b>	Section 2	Section 3	Section 4	Section 5

## 1.3 System Description

The RaySol system consists of:

- RaySol 1 or RaySol 2 heating cable (RaySol 1 for 110-volt to 120-volt applications; RaySol 2 for 208-volt to 277-volt applications)
- RaySol termination components
- UL Listed or CSA Certified junction box (not supplied by Raychem)
- Ground-fault protection device (TraceGuard 277™ GFPD supplied by Raychem)
- Optional automatic controls (not supplied by Raychem)

## 1.4 Codes and Approvals

Paragraphs 424–44 and 424–45 of the 1993 National Electrical Code govern the installation of RaySol heating cable for concrete and mortar floors. All designs must also comply with all applicable local codes and standards.

RaySol heating cable shall be applied only to fire-resistant materials, and shall not be installed in ceilings or walls.

RaySol is UL Listed as a Radiant Heating Cable for installation in mortar; in conduit embedded in concrete, sand, or soil; or for surface mounting to the bottom of concrete floors.

RaySol is CSA Certified for use in conduit embedded in concrete floor and directly embedded in mortar.

## 1.5 Warranty

The instructions in this manual and in the product packages, as well as all relevant local and national codes, must be followed. The Raychem warranty does not apply in the event of damage caused by accident, misuse, neglect, alteration, or improper installation, repair, or testing. See the Raychem warranty (Appendix A) for details.

Now turn to the appropriate section in this design guide as indicated in Table 1.1.

## 2. Heat-Loss Replacement

### 2.1 Application

This section presents design recommendations for a RaySol heat-loss replacement system for concrete floors built over garages, loading docks, arcades, or other cold spaces.

The design goal is to prevent the floor over a cold space from cooling below room temperature. The RaySol system achieves this by replacing the heat normally lost through the floor insulation over a cold space.

The heating cable either is attached directly to the bottom of the concrete floor or is installed in conduit that is embedded in the concrete floor.

This section covers the most typical concrete-floor heat-loss-replacement applications. For other applications, refer to Table 1.1 in Section 1. For applications not covered in this design guide, contact your Raychem representative for design assistance.

### 2.2 Heating Cable and Components

Table 2.1 lists the cables and components that are used for concrete-floor heat-loss-replacement applications.

**Table 2.1. Heating Cables and Components**

Description	Catalog number
Heating cable:	
110–120 V	RaySol 1
208–277 V	RaySol 2
Power connection and end seal:	
For cable attached to bottom of floor	FTC-P
For cable installed in conduit	FTC-XC
End seal	FTC-E
Splice:	
For cable attached to bottom of floor or for intermediate pull boxes	GMK-S or FTC-HST

### 2.3 Design Assumptions

The information and recommendations in this section are based on the following design assumptions:

- The floor to be heated is indoors where the room temperature above the floor is approximately 70°F.
- The bottom of the floor is insulated.
- The heating cable is attached to the bottom of, or installed in conduit embedded in, a standard concrete floor.

If any of these design assumptions do not apply to your application, contact your Raychem representative for design assistance.

## 2. Heat-Loss Replacement

### 2.4 Design: Determining Heating Cable Spacing

#### Determine Installation Method

The heating cable may be installed in one of two ways: fixed to the bottom of the floor (Figure 2.1) or installed inside electrical conduit that is buried in the floor (Figure 2.2). Attaching the heating cable directly to the bottom of the concrete floor (Figure 2.1) is the preferred method. If the bottom of the concrete floor is not accessible, the RaySol heating cable should be installed in a UL Listed or CSA Certified electrical conduit embedded in the concrete.

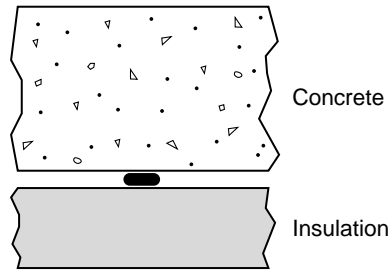

**Figure 2.1.** Heating cable attached to the bottom of the floor.

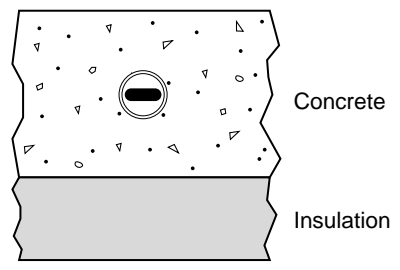

**Figure 2.2.** Heating cable inside electrical conduit embedded in the floor.

#### Determine Design Minimum Ambient Temperature

The design minimum ambient temperature is the lowest temperature expected below the floor insulation.

This can be determined by using the ASHRAE 97 1/2% Winter Dry-Bulb Design Temperature. Alternatively, if other reliable sources of information are available, they can be used at the designer's discretion.

Design minimum ambient temperature (°F)

#### Record Insulation R-Value

The insulation R-value is the thermal resistance of the floor's insulation. Normally the R-value will be printed on the insulation material. However, if that is not the case, you can calculate it by dividing the insulation thickness (in inches) by the insulation thermal conductivity.

Insulation R-value (h-ft<sup>2</sup>/Btu)

#### Determine Heating Cable Spacing

Use the design minimum ambient temperature and the floor insulation R-value to select a value from Table 2.2 on the next page. If your calculated R-value or design minimum ambient temperature does not match the values in Table 2.2, use the values that give the closer heating cable spacing.

If the concrete floor is placed directly on grade, install the cable on 30-inch centers.



## 2. Heat-Loss Replacement

If the space below the floor is maintained at 50°F to 70°F, insulate the floor to R-10 minimum and select a heating cable spacing from the 50°F row in Table 2.2.

**Table 2.2. Heating Cable Spacing (in inches)**

Lowest temperature below floor	Floor insulation R-Value (h-ft <sup>2</sup> /Btu)			
	R-10	R-20	R-30	R-40
50°F	30	36	36	36
30°F	24	30	36	36
10°F	21	30	30	36
-10°F	18	24	30	36
-30°F	15	24	30	36

Cable spacing (inches)

### 2.5 Layout: Laying Out Heating Cable and Components

#### Prepare Scale Drawing

In preparation for laying out each heating cable circuit, draw to scale the floor area to be heated. Carefully note the limits of the area to be heated. Show all concrete joints on the drawing and note the location and size of obstacles, such as floor drains, pipe penetrations, conduit runs, columns, and fixtures.

#### Estimate Number of Circuits

For heating cable attached to the bottom of the floor, use the procedure that follows. For heating cable in conduit, refer to Section 5.5 on page 25.

The length of heating cable and the number of heating cable circuits can be estimated before a detailed layout is done if the heating cable spacing, total heated area, and the available branch circuit breaker rating are known.

Estimate the total heating cable length as follows:

$$\text{Est. heating cable length (ft)} = \frac{\text{ft}^2 \text{ of heated floor} \times 12}{\text{Heating cable spacing (in.)}} + \text{End allowances (ft)} + \text{Component allowances (ft)}$$

The end allowance (usually 48 inches per end) is the length of heating cable installed in protective conduit between the heated floor and the power connection junction box. The component allowance (usually 24 inches per end) is the length of heating cable inside the power connection junction box.

Estimated heating cable length (feet)

Based on the rating of the circuit breaker and voltage, determine the maximum length of heating cable allowed per circuit breaker from Table 2.3.

**Table 2.3. Maximum Circuit Length in Feet (40°F Start-up)\***

Circuit breaker rating	Cable operating voltage				
	120 V	208 V	220 V	240 V	277 V
30 amps	240	410	410	425	430
20 amps	160	275	275	280	290
15 amps	120	205	205	210	215

\*For start-up temperatures less than 40°F, contact your Raychem representative.

Maximum circuit length (feet)

## 2. Heat-Loss Replacement

Calculate the estimated number of circuits as follows:

$$\text{Estimated number of circuits} = \frac{\text{Total cable length}}{\text{Maximum circuit length}}$$

Round the number of circuits to the next larger whole number.

Estimated number of circuits

### Locate Junction Boxes

The heating cable connects to the branch circuit wiring in a junction box by means of a power connection and end seal—either a RaySol FTC-P for cable attached to the bottom of the floor or a RaySol FTC-XC for cable placed in conduit.

The junction boxes may be distributed around the area to be heated, or collected at a single location. In many applications the heating cable can be laid out so that all power connections and end seals can be grouped in a common area without using extra heating cable. If this can be done, select the common junction box location to minimize the electrical conduit and wire needed to reach the branch circuit breakers. Refer to Figure 2.3 for examples of typical layouts of cable attached to the bottom of concrete floors.

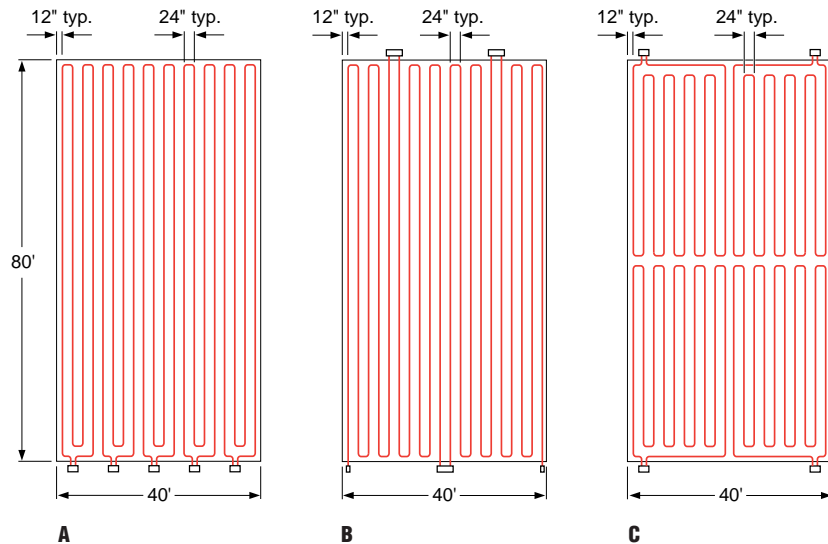

**Figure 2.3. Typical layouts for heating cable attached to the bottom of concrete floors (for typical conduit layout, refer to Figures 5.2 and 5.3 on page 27)**

### Lay Out Heating Cable

After determining the approximate total length of heating cable, the number of circuits, and the junction box location, do a trial layout. In making the trial layout, follow these recommendations:

- Start and end each circuit in a junction box. The power connection and end seal may be located in the same box or in different boxes.
- Do not design more than one run of heating cable per conduit.
- Arrange the heating cable in a serpentine pattern to uniformly cover the area to be heated.
- Maintain the design heating cable spacing within 1 inch.
- Do not extend the heating cable beyond the room or area in which it originates.
- Do not cross expansion, crack control, or other joints.

## 2. Heat-Loss Replacement

- Do not route the heating cable closer than 4 inches to the edge of the concrete floor, drains, anchors, or other material in the concrete.
- Do not exceed the maximum length of heating cable allowed on a branch circuit breaker as determined from Table 2.3. The maximum length includes the heating cable covering the floor as well as the heating cable included in the junction box and protective conduit.
- If the heating cable is to be installed in conduit, the maximum length of heating cable that can be pulled is 450 feet. The maximum total degree of conduit turn is 360 degrees.
- Do not install RaySol heating cable in ceilings or walls.

### Record Circuit Information

Reconstruct the trial circuit layout until the design meets all of the previous recommendations. Record the total length of heating cable used on each circuit. Assign each circuit to a circuit breaker in a specific panel board and record each circuit length.

Actual cable length per circuit (feet)

### 2.6 Electrical Design: Selecting and Sizing Electrical Parameters

#### Select Cable

Select the RaySol heating cable that matches your operating voltage:

- RaySol 1: 110–120 volts
- RaySol 2: 208–277 volts

Cable

#### Record Branch Circuit Breaker Rating

Record the circuit breaker rating to be used.

Use ground-fault protection devices (GFPDs) for all RaySol applications.

Ground-fault protection devices with a 30-mA trip level are available from Westinghouse (GFEPD) and Square-D (QO-EPD). If operating at 277 volts, use a Raychem TraceGuard 277™ GFPD.

**⚠ WARNING: To minimize the danger of fire from sustained electrical arcing if the heating cable is damaged or improperly installed, use a ground-fault protection device (GFPD) with a nominal 30-milliampere (mA) trip level. Arcing may not be stopped by conventional circuit breakers.**

Circuit breaker rating (amps)

#### Select Maximum Length of Heating Cable per Branch Circuit

Based on the layout and using the circuit breaker rating, select from Table 2.3 the maximum length of heating cable allowed on a branch circuit.

Maximum circuit length (feet)

#### Select Junction Box

For the heating cable power connection and end seal, select a UL Listed or CSA Certified junction box that is suitable for the location. Use a box with a minimum internal volume of 16 cubic inches if the box is metallic and 19 cubic inches if the box is not metallic.

The junction box containing the RaySol power connection and end seal must be accessible. According to the National Electrical Code, “accessible” is defined as 1) capable of being removed or exposed without damaging the building structure or finish, or 2) not permanently closed in by the structure or finish of the building. Refer to Article 370-19 of the National Electrical Code for restrictions on junction box location.

## 2. Heat-Loss Replacement

### Size Transformer

Calculate the total transformer load as:

$$\text{Transformer load (W)} = 0.8 \times \text{Circuit breaker rating (A)} \times \frac{\text{Total cable length (ft)}}{\text{Maximum circuit length (ft)}} \times \text{Voltage}$$

Transformer load (watts)

### Select Controls (optional)

For situations where controls are desired, there are three types of controls that may be used with heat-loss-replacement systems:

- Manual control
- Ambient temperature control
- Floor temperature sensing control

#### **Manual control**

With manual control, the heating system is switched on and off using either a manual switch or a circuit breaker. The system can also be energized continuously.

#### **Ambient temperature control**

With ambient temperature control, the heat-loss-replacement system is controlled by an ambient-air-temperature-sensing thermostat, such as Raychem AMC-1A. When the outside air temperature drops below a preset temperature, usually 40°F, the heating cable is energized.

#### **Floor temperature sensing control**

By utilizing a thermostat with a sensing bulb embedded in the floor, the temperature of the floor can be controlled directly.

### 2.7 Example

This example is based on Figure 2.3-A on page 6. It represents a heat-loss replacement application where the minimum ambient temperature below the floor is -10°F and the floor is insulated to R-20. The heating cable will be attached to the bottom surface of the floor.

Twenty-four-inch heating cable spacing was selected from Table 2.2 on page 5. Twenty-four inches of heating cable per end was allowed for the component allowance and 48 inches per end for the end allowance.

The estimated heating cable length is calculated as follows (based on the formula on page 5):

$$\text{Estimated heating cable length} = \frac{40 \text{ ft} \times 80 \text{ ft} \times 12}{24 \text{ in}} + 40 \text{ ft} + 20 \text{ ft} = 1660 \text{ ft}$$

The initial estimate for the number of circuits was four. However, after the layout was finalized, the actual length of heating cable used was 1665 feet in five circuits, making the length of cable per circuit 333 feet.

The circuit breaker rating is 30 amps, the voltage is 277 Vac, and the maximum circuit length from Table 2.3 is 430 feet.

The transformer load per circuit is calculated as follows (based on the formula on this page):

$$\text{Transformer load} = 0.8 \times 30 \text{ A} \times \frac{333 \text{ ft}}{430 \text{ ft}} \times 277 \text{ Vac} = 5148 \text{ W}$$

## 3. Concrete Floor Warming

### 3.1 Application

This section presents design recommendations for a concrete floor warming system using RaySol heating cables for bathrooms, foyers, schools, or gymnasiums.

The design goal is to raise the floor temperature to 80°F or above so it is comfortable to walk on the floor in bare feet.

The heating cable either is attached directly to the bottom of the concrete floor or is installed inside conduit that is embedded in the concrete floor.

This section covers the most typical concrete floor warming applications. For other applications, refer to Table 1.1 in Section 1. For applications not covered in this design guide, contact your Raychem representative for design assistance.

### 3.2 Heating Cable and Components

Table 3.1 lists the cables and components that are used for concrete floor warming applications.

**Table 3.1. Heating Cables and Components**

Description	Catalog number
Heating cable:	
110–120 V	RaySol 1
208–277 V	RaySol 2
Power connection and end seal:	
For cable attached to bottom of floor	FTC-P
For cable installed in conduit	FTC-XC
End seal	FTC-E
Splice:	
For cable attached to bottom of floor or for intermediate pull boxes	GMK-S or FTC-HST

### 3.3 Design Assumptions

The information and recommendations in this section are based on the following design assumptions:

- The floor to be heated is indoors where the room temperature above the floor is approximately 70°F.
- The bottom of the floor is insulated.
- The heating cable is attached to the bottom of, or installed in conduit embedded in, standard concrete floor.

If any of these design assumptions do not apply to your application, contact your Raychem representative for design assistance.

### 3. Concrete Floor Warming

#### 3.4 Design: Determining Heating Cable Spacing

##### Determine Installation Method

The heating cable may be installed in one of two ways: fixed to the bottom of the floor (Figure 3.1) or installed inside electrical conduit that is buried in the floor (Figure 3.2). Attaching the heating cable directly to the bottom of the concrete floor (Figure 3.1) is the preferred method. If the bottom of the concrete floor is not accessible, the RaySol heating cable should be installed in a UL Listed or CSA Certified electrical conduit embedded in the concrete.

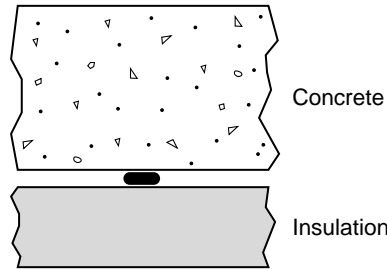

**Figure 3.1. Heating cable attached to the bottom of the floor.**

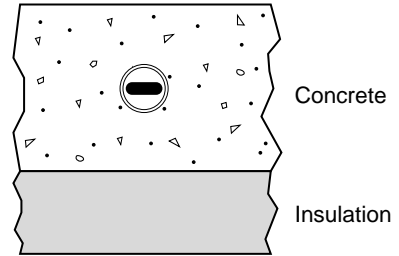

**Figure 3.2. Heating cable inside electrical conduit embedded in the floor.**

Since the power output of a self-regulating cable varies with the method of installation, the heating cable spacing table (Table 3.2 on the next page) shows a different value for each method.

##### Determine Design Minimum Ambient Temperature

The design minimum ambient temperature is the lowest temperature expected below the floor insulation.

This can be determined by using the ASHRAE 97 1/2% Winter Dry-Bulb Design Temperature. Alternatively, if other reliable sources of information are available, they can be used at the designer's discretion.

Design minimum ambient temperature (°F)

##### Record Insulation R-Value

The insulation R-value is the thermal resistance of the floor's insulation. Normally the R-value will be printed on the insulation material. However, if that is not the case, you can calculate it by dividing the insulation thickness in inches by the insulation thermal conductivity.

Insulation R-value (h-ft<sup>2</sup>/Btu)

### 3. Concrete Floor Warming

#### Determine Heating Cable Spacing

Use the design minimum ambient temperature, the floor insulation R-value, and the installation method to select the correct heating-cable spacing from Table 3.2 below. If your calculated R-value or design minimum ambient temperature does not match the values in Table 3.2, use the values that give you the closer heating cable spacing.

For on-grade installations use heating cable on 6-inch centers if the heating cable is installed in conduit.

If the space below the floor is maintained at 50°F to 70°F, insulate the floor to R-10 minimum and select a heating cable spacing from the 50°F row in Table 3.2.

**Table 3.2. Heating Cable Spacing (in inches)**

Lowest temperature below floor	Installation method	Floor insulation R-value (h-ft <sup>2</sup> /Btu)			
		R-10	R-20	R-30	R-40
50°F	Surface	8	9	9	9
	Conduit	6	6	6	6
30°F	Surface	7	8	9	9
	Conduit	5	6	6	6
10°F	Surface	7	8	9	9
	Conduit	5	5	6	6
-10°F	Surface	6	8	8	9
	Conduit	4	5	5	6
-30°F	Surface	6	7	8	8
	Conduit	4	5	5	6

Cable spacing (inches)

#### 3.5 Layout: Laying Out Heating Cable and Components

#### Prepare Scale Drawing

In preparation for laying out each heating cable circuit, draw to scale the floor area to be heated. Carefully note the limits of the area to be heated. Show all concrete joints on the drawing and note the location and size of obstacles, such as floor drains, pipe penetrations, conduit runs, columns, and fixtures.

#### Estimate Number of Circuits

For heating cable attached to the bottom of the floor, use the procedure that follows. For heating cable in conduit, refer to Section 5.5 on page 25.

The length of heating cable and the number of heating cable circuits can be estimated before a detailed layout is done if the heating cable spacing, total heated area, and the available branch circuit breaker rating are known. Estimate the total heating cable length as follows:

$$\text{Est. heating cable length (ft)} = \frac{\text{ft}^2 \text{ of heated floor} \times 12}{\text{Heating cable spacing (in)}} + \text{End allow-ances (ft)} + \text{Component allowances (ft)}$$

The end allowance (usually 48 inches per end) is the length of heating cable installed in protective conduit between the heated floor and the power connection junction box. The component allowance (usually 24 inches per end) is the length of heating cable inside the power connection junction box.

Estimated heating cable length (feet)

### 3. Concrete Floor Warming

Based on the rating of the circuit breaker and voltage, determine the maximum length of heating cable allowed per circuit breaker from Table 3.3.

**Table 3.3. Maximum Circuit Length in Feet (40°F Start-up)\***

Circuit breaker rating	Cable operating voltage				
	120 V	208 V	220 V	240 V	277 V
30 amps	240	410	410	425	430
20 amps	160	275	275	280	290
15 amps	120	205	205	210	215

\*For start-up temperatures less than 40°F, contact your Raychem representative.

Maximum circuit length (feet)

Calculate the estimated number of circuits as follows:

$$\text{Estimated number of circuits} = \frac{\text{Total cable length}}{\text{Maximum circuit length}}$$

Round the number of circuits to the next larger whole number.

Estimated number of circuits

#### Locate Junction Boxes

The heating cable connects to the branch circuit wiring in a junction box using a power connection and end seal—either a RaySol FTC-P for cable attached to the bottom of the floor or FTC-XC for cable placed in conduit.

The junction boxes may be distributed around the area to be heated, or collected at a single location. In many applications the heating cable can be laid out so that all power connections and end seals can be grouped in a common area without using extra heating cable. If this can be done, select the common junction box location to minimize the wire needed to reach the branch circuit breakers. Refer to figure 3.3 for examples of typical layouts of cable attached to the bottom of concrete floors.

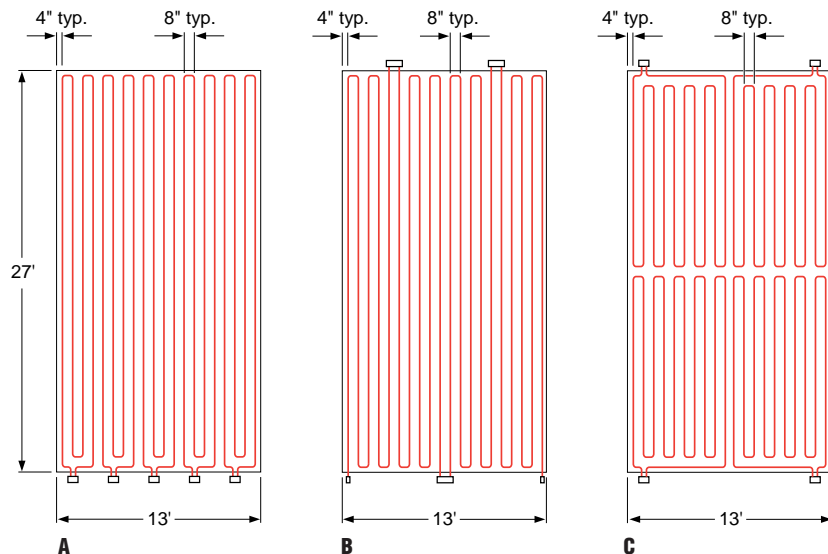

**Figure 3.3. Typical layouts for heating cable attached to the bottom of concrete floors (for typical conduit layout, refer to Figures 5.2 and 5.3 on page 27)**



### 3. Concrete Floor Warming

#### Lay Out Heating Cable

After determining the approximate total length of heating cable, the number of circuits, and the junction box location, do a trial layout. In making the trial layout, follow these recommendations:

- Start and end each circuit in a junction box. The power connection and end seal may be located in the same box or in different boxes.
- Do not design more than one run of heating cable per conduit.
- Arrange the heating cable in a serpentine pattern to cover the area to be heated uniformly.
- Maintain the design heating cable spacing within 1 inch.
- Do not extend the heating cable beyond the room or area in which it originates.
- Do not cross expansion, crack control, or other joints.
- Do not route the heating cable closer than 4 inches to the edge of the concrete floor, drains, anchors, or other material in the concrete.
- Do not exceed the maximum circuit length of heating cable allowed on a branch circuit breaker as determined from Table 3.3. The maximum length includes the heating cable covering the floor as well as the heating cable included in the junction box and protective conduit.
- If the heating cable is to be installed in conduit, the maximum length of heating cable that can be pulled is 450 feet. The maximum total degree of conduit turn is 360 degrees.
- Do not install RaySol heating cable in ceilings or walls.

#### Record Circuit Information

Reconstruct the trial circuit layout until the design meets all of the recommendations noted above. Record the total length of heating cable used on each circuit. Assign each circuit to a circuit breaker in a specific panel board and record each circuit length.

Actual cable length per circuit (feet)

#### 3.6 Electrical Design: Selecting and Sizing Electrical Parameters

#### Select Cable

Select the RaySol heating cable that matches your operating voltage:

- RaySol 1: 110–120 volts
- RaySol 2: 208–277 volts

Cable

#### Record Branch Circuit Breaker Rating

Record the circuit breaker rating to be used.

Use ground-fault protection devices (GFPDs) for all RaySol applications. Ground-fault protection devices with a 30-mA trip level are available from Westinghouse (GFEPD) and Square-D (QO-EPD). If operating at 277 volts, use a Raychem TraceGuard 277 GFPD.



**WARNING: To minimize the danger of fire from sustained electrical arcing if the heating cable is damaged or improperly installed, use a ground-fault protection device (GFPD) with a nominal 30-milliampere (mA) trip level. Arcing may not be stopped by conventional circuit breakers.**

Circuit breaker rating (amps)

### 3. Concrete Floor Warming

#### Select Maximum Length of Heating Cable per Branch Circuit

Based on the layout and using the circuit breaker rating, select from Table 3.3 the maximum length of heating cable allowed on a branch circuit.

Maximum circuit length (feet)

#### Select Junction Box

For the heating cable power connection and end seal, select a UL Listed or CSA Certified junction box suitable for the location. Use a box with a minimum internal volume of 16 cubic inches if the box is metallic and 19 cubic inches if the box is not metallic.

The junction box containing the RaySol power connection and end seal must be accessible. According to the National Electrical Code, “accessible” is defined as 1) capable of being removed or exposed without damaging the building structure or finish, or 2) not permanently closed in by the structure or finish of the building. Refer to Article 370-19 of the National Electrical Code for restrictions on junction box location.

#### Size Transformer

Calculate the total transformer load as:

$$\text{Transformer load (W)} = 0.8 \times \frac{\text{Circuit breaker rating (A)}}{\text{Maximum circuit length (ft)}} \times \text{Total cable length (ft)} \times \text{Voltage}$$

Transformer load (watts)

#### Select Controls (optional)

For situations where controls are desired, there are three types of controls that may be used with concrete floor warming systems:

- Manual control
- Ambient temperature control
- Floor temperature sensing control

#### *Manual control*

With a manual control, the concrete floor warming system is switched on and off using either a manual switch or a circuit breaker. The system can also be energized continuously.

#### *Ambient temperature control*

With ambient temperature control, the concrete floor warming system is controlled by an ambient-air-temperature-sensing thermostat, such as Raychem AMC-1A. When the outside air temperature drops below a preset temperature, usually 40°F, the heating cable is energized. Ambient temperature control is normally used only with systems designed for floor heat loss replacement.

#### *Floor temperature sensing control*

By utilizing a thermostat with a sensing bulb embedded in the floor, the temperature of the floor can be controlled directly.

## 3. Concrete Floor Warming

### 3.7 Example

This example is based on Figure 3.3-A on page 12. It represents a concrete floor warming application where the minimum temperature below the floor is 30°F and the floor is insulated to R-20. The heating cable will be attached to the bottom surface of the floor.

Eight-inch heating cable spacing was selected from Table 3.2 on page 11. Twenty-four inches of heating cable per end was allowed for the component allowance and 48 inches per end for the end allowance.

The estimated heating cable length is calculated as follows (based on the formula on page 11):

$$\text{Estimated heating cable length} = \frac{13 \text{ ft} \times 27 \text{ ft} \times 12}{8 \text{ in}} + 40 \text{ ft} + 20 \text{ ft} = 587 \text{ ft}$$

The initial estimate for the number of circuits was three. However, after the layout was finalized, the actual length of heating cable used was 590 feet in five circuits, making the length of cable per circuit 118 feet.

The circuit breaker rating is 15 amps, the voltage is 220 Vac, and the maximum circuit length from Table 3.3 is 205 feet.

The transformer load per circuit is calculated as follows (based on the formula on page 14):

$$\text{Transformer load} = 0.8 \times 15 \text{ A} \times \frac{118 \text{ ft}}{205 \text{ ft}} \times 220 \text{ Vac} = 1520 \text{ W}$$



## 4. Tile and Marble Floor Warming

### 4.1 Application

This section presents design recommendations for tile and marble floor warming systems using RaySol 1 heating cable for bathrooms and foyers.

The design goal is to raise the floor surface temperature above 80°F, making it comfortable to walk on with bare feet.

RaySol 1 heating cable is embedded in the mortar setting bed under a tile or marble floor. Do not install it in showers or under bath tubs.

This section covers the most typical tile and marble floor warming applications. If your application is not covered here, please refer to Table 1.1 in section 1. For applications not covered in this design guide, contact your Raychem representative for design assistance.

### 4.2 Heating Cable and Components

Table 4.1 lists the cables and components that are used in tile and marble floor warming applications.

**Table 4.1. Heating Cable and Components**

Description	Catalog number
Heating cable (110–120 V)	RaySol 1
Power connection and end seal	FTC-XC
End seal	FTC-E
Splice (for intermediate pull boxes)	GMK-S or FTC-HST

## 4. Tile and Marble Floor Warming

### 4.3 Design Assumptions

The information and recommendations in this section are based on the following design assumptions:

- The floor to be heated is indoors where the room temperature above the floor is approximately 70°F.
- The bottom of the floor is insulated or located on grade.
- The heating cable is embedded in standard-density mortar. Lightweight, dry-set mortar such as Gypcrete is not considered standard.
- The minimum thickness of the mortar is 1 inch.
- The heating cable shall not be installed in shower floors.

If any of these design assumptions do not apply to your application, contact your Raychem representative for design assistance.

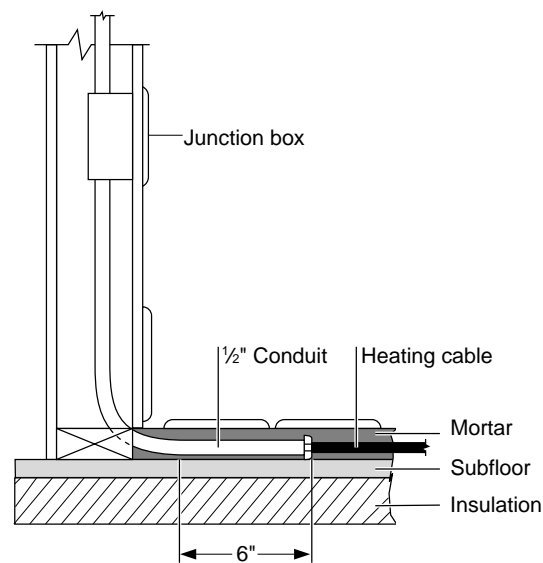

**Figure 4.1. Typical tile and marble installation**

### 4.4 Design: Determining Heating Cable Spacing

#### Determine Design Minimum Ambient Temperature

The design minimum ambient temperature is the lowest temperature expected below the floor insulation.

This can be determined by using the ASHRAE 97 1/2% Winter Dry-Bulb Design Temperature. Alternatively, if other reliable sources of information are available, they can be used at the designer's discretion.

Design minimum ambient temperature (°F)

## 4. Tile and Marble Floor Warming

### Record Insulation R-Value

The insulation R-value is the thermal resistance of the floor's insulation. Normally the R-value will be printed on the insulation material. However, if that is not the case, you can calculate it by dividing the insulation thickness in inches by the insulation thermal conductivity.

Insulation R-value (h-ft<sup>2</sup>/Btu)

### Determine Heating Cable Spacing

Use the design minimum ambient temperature and the floor insulation R-value to select the correct heating cable spacing from Table 4.2. If your calculated R-value or design minimum ambient temperature does not match the values in Table 4.2, use the values that give the closer heating cable spacing.

For on-grade installations use heating cable on 9-inch centers.

If the space below the floor is maintained at more than 50°F, insulate the floor to R-10 minimum and select a heating cable spacing from the 50°F row in Table 4.2.

**Table 4.2. Heating Cable Spacing (in inches)**

Temperature below floor	Floor insulation R-Value (h-ft <sup>2</sup> /Btu)			
	R-10	R-20	R-30	R-40
50°F	8	9	9	9
30°F	7	8	8	8
10°F	7	7	8	8
-10°F	6	7	7	8
-30°F	6	7	7	7

Cable spacing (inches)

### 4.5 Layout: Laying Out Heating Cable and Components

#### Prepare Scale Drawing

In preparation for laying out each heating cable circuit, draw to scale the floor area to be heated. Note the limits of the heated area carefully. Show all concrete joints on the drawing and note the location and size of obstacles such as floor drains, pipe penetrations, conduit runs, columns, and fixtures.

#### Estimate Number of Circuits

The length of heating cable and the number of heating cable circuits can be estimated before a detailed layout is done if the heating cable spacing, total heated area, and the available branch circuit breaker rating are known. Estimate the total heating cable length as:

$$\text{Est. heating cable length (ft)} = \frac{\text{ft}^2 \text{ of heated floor} \times 12}{\text{Heating cable spacing (in)}} + \text{End allowances (ft)} + \text{Component allowances (ft)}$$

The end allowance (usually 48 inches per end) is the length of heating cable installed in protective conduit between the heated floor and the power connection junction box. The component allowance (usually 24 inches per end) is the length of heating cable inside the power connection junction box.

Estimated heating cable length (feet)

## 4. Tile and Marble Floor Warming

Based on the rating of the circuit breaker, determine the maximum length of heating cable allowed per circuit breaker from Table 4.3.

**Table 4.3. Maximum Circuit Length in Feet (40°F Start-up)\***

Circuit breaker rating	RaySol circuit length
30 amps	160
20 amps	105
15 amps	80

\*For start-up temperatures less than 40°F, contact your Raychem representative.

Maximum circuit length (feet)

Calculate the estimated number of circuits as follows:

$$\text{Estimated number of circuits} = \frac{\text{Total cable length}}{\text{Maximum circuit length}}$$

Round the number of circuits to the next larger whole number.

Estimated number of circuits

### Locate Junction Boxes

The heating cable connects to the branch circuit wiring in a junction box by means of a RaySol FTC-XC power connection and end seal.

The junction boxes may be distributed around the area to be heated, or collected at a single location. In many applications the heating cable can be laid out so that all power connections and end seals can be grouped in a common area without using extra heating cable. If this can be done, select the common junction box location to minimize the electrical conduit and wire needed to reach the branch circuit breakers.

### Lay Out Heating Cable

After determining the approximate total length of heating cable, the number of circuits, and the junction box location, do a trial layout. In making the trial layout follow these recommendations:

- Start and end each circuit in a junction box. The power connection and end seal may be located in the same box or in different boxes.
- Do not design more than one run of heating cable per conduit.
- Arrange the heating cable in a serpentine pattern to cover the area to be heated uniformly.
- Maintain the design heating cable spacing within 1 inch.
- Do not extend the heating cable beyond the room or area in which it originates.
- Do not cross expansion, crack control, or other joints.
- Do not route the heating cable closer than 4 inches to the edge of the tile or marble floor, drains, anchors, or other material in the setting bed.
- Do not exceed the maximum length of heating cable allowed on a branch circuit breaker as given in Table 4.3. The maximum length includes the heating cable covering the floor as well as the heating cable included in the junction box and protective conduit.
- Do not install RaySol heating cable in ceilings or walls.
- Do not bury splices in mortar. Splices can only be used in intermediate pull boxes.



## 4. Tile and Marble Floor Warming

### Record Circuit Information

Reconstruct the trial circuit layout until the design meets all of the previous recommendations. Record the total length of heating cable used on each circuit. Assign each circuit to a circuit breaker in a specific panel board and record each circuit length.

Actual cable length per circuit (feet)

### 4.6 Electrical Design: Selecting and Sizing Electrical Parameters

#### Select Cable

RaySol 1 cable is suitable for operating voltages of 110 to 120 Vac.

Cable

RaySol 1

#### Select Branch Circuit Breaker Rating

Record the circuit breaker rating to be used.

Use ground-fault protection devices (GFPDs) for all RaySol applications.

**⚠ WARNING: To minimize the danger of shock or of fire from sustained electrical arcing if the heating cable is damaged or improperly installed, use a ground-fault protection device (GFPD) with a nominal 5-milliampere (mA) trip level. Arcing may not be stopped by conventional circuit breakers.**

Circuit breaker rating (amps)

#### Select Maximum Length of Heating Cable per Branch Circuit

Based on the layout and using the circuit breaker rating, select from Table 4.3 the maximum length of heating cable allowed on a branch circuit.

Maximum circuit length (feet)

#### Select Junction Box

For the heating cable power connection and end seal, select a UL Listed or CSA Certified junction box that is suitable for the location. Use a box with a minimum internal volume of 16 cubic inches if the box is metallic and 19 cubic inches if the box is not metallic.

The junction box containing the RaySol power connection and end seal must be accessible. According to the National Electrical Code, "accessible" is defined as 1) capable of being removed or exposed without damaging the building structure or finish, or 2) not permanently closed in by the structure or finish of the building. Refer to Article 370-19 of the National Electrical Code for restrictions on junction box location.

#### Size Transformer

Calculate the total transformer load as:

$$\text{Transformer load (W)} = 0.8 \times \text{Circuit breaker rating (A)} \times \frac{\text{Total cable length (ft)}}{\text{Maximum circuit length (ft)}} \times \text{Voltage}$$

Transformer load (watts)

## 4. Tile and Marble Floor Warming

### Select Controls (optional)

The RaySol 1 heating cable has a start-up characteristic similar to that of an incandescent lighting load. Any control used to switch the heating cable should be suitable for incandescent loads and should have an ampacity equal to that of the branch circuit.

### Manual control

It is common for floor-warming systems to be operated 24 hours a day without any temperature controls other than the inherent self-regulating action of the RaySol 1 heating cable. When operated without external temperature controls the maximum floor temperature will be between 85°F and 95°F. If the heating cable is to be switched by a time clock, set the clock to energize the system about two hours before the floor needs to be warm to allow time for warm-up.

### Thermostatic control

By utilizing a thermostat with a sensing bulb embedded in the floor, the temperature of the floor can be controlled directly. For direct temperature control use a thermostat with a remote sensing bulb similar to the Raychem AMC-1B. Locate the thermostat sensing bulb at the same elevation as the heating cable and midway between adjacent runs of cable. Keep the sensing bulb as far from the walls of the room as possible. Install the sensing bulb inside PVC conduit so that the bulb can be removed if service is ever necessary.

### 4.7 Example

This example is based on a bathroom (10 feet x 10 feet) where the lowest temperature underneath the floor is 10°F and the floor is insulated to R-10. The circuit breaker rating is 30 amps and the voltage is 120 Vac.

Seven-inch heating cable spacing was selected from Table 4.2 on page 19. Twenty-four inches of heating cable per end was allowed for the component allowance, and 48 inches per end for the end allowance.

The total heating cable length is calculated as follows (based on the formula on page 19):

$$\text{Estimated heating cable length} = \frac{10 \text{ ft} \times 10 \text{ ft} \times 12}{7 \text{ in}} + 8 \text{ ft} + 4 \text{ ft} = 183 \text{ ft}$$

After the layout was finalized, the actual length of heating cable used was 190 feet in two circuits, making the length of cable per circuit 95 feet.

The circuit breaker rating is 30 amps, the voltage is 120 Vac, and the maximum circuit length from Table 4.3 is 160 feet.

The transformer load per circuit is calculated as follows (based on the formula on page 21):

$$\text{Transformer load} = 0.8 \times 30 \text{ A} \times \frac{95 \text{ ft}}{160 \text{ ft}} \times 120 \text{ Vac} = 1710 \text{ W}$$

## 5. Freezer Frost Heave Prevention

### 5.1 Application

This section presents design recommendations for RaySol freezer-floor frost-heave-prevention systems. The heating cable is installed inside electrical conduit embedded in concrete, sand, or soil.

Subfreezing temperatures inside cold rooms and freezers cause heat to be lost from the soil under the floor, even when it is well insulated. As the soil freezes, capillary action draws water into the frozen areas where the water forms a concentrated ice mass. As the ice mass grows, it heaves the freezer floor and columns, causing damage.

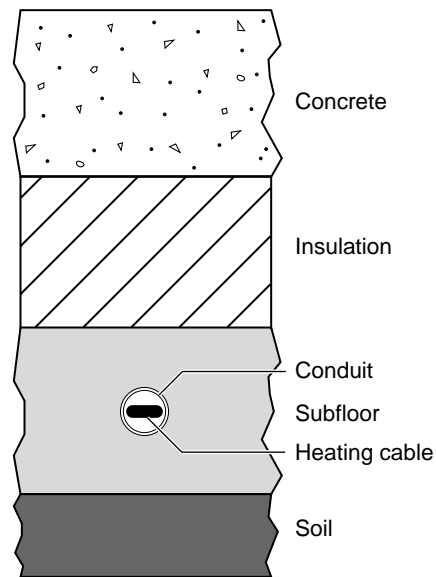

**Figure 5.1. Typical freezer frost prevention installation**

The electrical conduit carrying the RaySol heating cable may be installed in the subfloor under the freezer-floor insulation, as illustrated in Figure 5.1. The subfloor layer may be a reinforced concrete slab, a concrete mud slab, a bed of compacted sand, or simply compacted fill. The conduit spacing will vary from 96 inches to 30 inches, depending on the design conditions.

This section covers the most typical freezer-frost-heave-prevention applications. For other applications, refer to Table 1.1 in Section 1. For applications not covered in this design guide, contact your Raychem representative for design assistance.

## 5. Freezer Frost Heave Prevention

### 5.2 Heating Cable and Components

Table 5.1 lists the cables and components that are used for freezer-frost-heave-prevention applications.

**Table 5.1. Heating Cables and Components**

Description	Catalog number
Heating cable: 110–120 V	RaySol 1
208–277 V	RaySol 2
Power connection and end seal	FTC-XC
End seal	FTC-E
Splice (for intermediate pull boxes)	GMK-S or FTC-HST

### 5.3 Design Assumptions

The information and recommendations in this section are based on the following design assumptions:

- Any size freezer or cold room operating below 32°F will experience frost heaving.
- The bottom of the floor is insulated and located on grade.
- The heating cable is in conduit embedded in concrete, sand, or soil. If you are using a different medium, contact Raychem for an analysis.

If any of these design assumptions do not apply to your application, contact your Raychem representative for design assistance.

### 5.4 Design: Determining Heating Cable Spacing

#### Determine Freezer Temperature

Determine the temperature at which your freezer operates.

If it operates at more than one temperature, or if the operating temperature may be changed in the future, base the spacing selection on the lowest anticipated operating temperature.

Freezer temperature (°F)

#### Record Insulation R-Value

The insulation R-value is the thermal resistance of the floor's insulation. Normally the R-value will be printed on the insulation material. However, if that is not the case, you can calculate it by dividing the insulation thickness in inches by the insulation thermal conductivity.

Insulation R-value (h-ft<sup>2</sup>/Btu)

#### Determine Conduit Spacing

Use the freezer operating temperature and the floor insulation R-value to select the correct conduit spacing from Table 5.2 on the next page. If your calculated R-value or freezer operating temperature does not match the values in Table 5.2, use the values that give the closer heating cable spacing.

Within each cell, there are two numbers, one for conduit spacing and one for freezer load.

Freezer load is the additional cooling load imposed on the cooling system by the freezer-frost-heave-prevention heating cable. It is the heat transferred through the insulation into the freezer, expressed in watts per square foot of floor area.

## 5. Freezer Frost Heave Prevention

**Table 5.2. Conduit Spacing and Freezer Load**

Freezer temperature		Floor insulation R-Value (h-ft <sup>2</sup> /Btu)			
		R-10	R-20	R-30	R-40
30°F	Conduit spacing	96	96	96	96
	Freezer load	0.7	0.4	0.3	0.3
20°F	Conduit spacing	81	96	96	96
	Freezer load	0.8	0.5	0.4	0.3
10°F	Conduit spacing	63	96	96	06
	Freezer load	1.0	0.6	0.4	0.3
0°F	Conduit spacing	51	84	96	96
	Freezer load	1.3	0.8	0.5	0.4
-10°F	Conduit spacing	42	72	96	96
	Freezer load	1.5	0.8	0.6	0.5
-20°F	Conduit spacing	36	63	87	96
	Freezer load	1.8	1.0	0.7	0.6
-30°F	Conduit spacing	33	57	78	93
	Freezer load	2.0	1.1	0.8	0.6
-40°F	Conduit spacing	30	51	69	84
	Freezer load	2.3	1.2	0.8	0.7

Note: Conduit spacing is expressed in inches; freezer load is expressed in watts per square foot (W/ft<sup>2</sup>).

Conduit spacing (inches)

Freezer load (W/ft<sup>2</sup>)

### 5.5 Layout: Laying Out Heating Cable and Components

#### Prepare Scale Drawing

In preparation for laying out each heating cable circuit, draw to scale the freezer floor area to be heated. Note the limits of the heated area carefully. Show all concrete joints on the drawing and note the location and size of obstacles such as floor drains, pipe penetrations, conduit runs, columns, and fixtures.

#### Estimate Number of Circuits

The amount of heating cable and the number of heating cable circuits can be estimated before a detailed layout is done if the conduit spacing, area dimensions, and the available branch circuit breaker rating are known.

Based on the rating of the circuit breaker and voltage, determine the maximum length of heating cable allowed per circuit breaker from Table 5.3, which follows.

**Table 5.3. Maximum Circuit Length in Feet (40°F Start-up)\***

Circuit breaker rating	Cable operating voltage				
	120 V	208 V	220 V	240 V	277V
30 amps	240	410	410	425	430
20 amps	160	275	275	280	290
15 amps	120	205	205	210	215

\*For start-up temperatures less than 40°F, contact your Raychem representative.

Maximum circuit length (feet)

## 5. Freezer Frost Heave Prevention

Let side "A" be the side the conduit runs parallel to. Side "A" cannot be greater than the maximum circuit length. Let side "B" be the side that is perpendicular to the conduit runs. Refer to Figures 5.2 and 5.3 for examples of side A and side B.

The number of estimated conduit runs is calculated as follows:

$$\text{Estimated number of conduit runs} = \frac{\text{Side B (ft)} \times 12}{\text{Conduit spacing (in)}}$$

Round the estimated number of conduit runs to the next larger whole number.

Estimated number of conduit runs

Estimate the total heating cable length as follows:

$$\text{Est. heating cable length (ft)} = \text{Side A (ft)} \times \text{Est. no. of conduit runs} + \text{End allowances (ft)} + \text{Component allowances (ft)}$$

Estimated heating cable length (feet)

The end allowance (usually 48 inches per end) is the length of heating cable installed in protective conduit between the heated floor and the power connection junction box. The component allowance (usually 24 inches per end) is the length of heating cable inside the power connection junction box.

When the maximum circuit length is greater than or equal to side A times two, then the conduit run can be looped into the hairpin layout (Figure 5.2). In a hairpin configuration, when you have an odd number of circuits, one circuit will be a straight run.

If maximum circuit length (ft)  $\geq 2 \times$  side A (ft), then

$$\text{Estimated number of circuits} = \frac{\text{Number of conduit runs}}{2}$$

When the maximum circuit length is less than side A times two, then use a straight run layout (Figure 5.3).

If maximum circuit length (ft)  $< 2 \times$  side A (ft), then

$$\text{Estimated number of circuits} = \text{Number of conduit runs}$$

Round the number of circuits to the next larger whole number.

Estimated number of circuits

### Locate Junction Boxes

The heating cable connects to the branch circuit wiring in a junction box using a RaySol FTC-XC power connection and end seal. The heating cable is routed from the subfloor to a junction box located above grade through protective conduit. In most freezer-frost-heave-prevention applications, separate junction boxes are used for the power connection and end seal.

## 5. Freezer Frost Heave Prevention

Two basic types of heating cable layouts are used:

- The hairpin layout (Figure 5.2) is used both in smaller freezers where it results in material and labor savings over the straight run layout (Figure 5.3), and in other freezers where only one wall of the freezer is accessible for mounting junction boxes.
- The straight run layout (Figure 5.3) is used when the freezer dimension exceeds one-half the maximum heating cable circuit length (insufficient heating cable allowed for a run down and back).

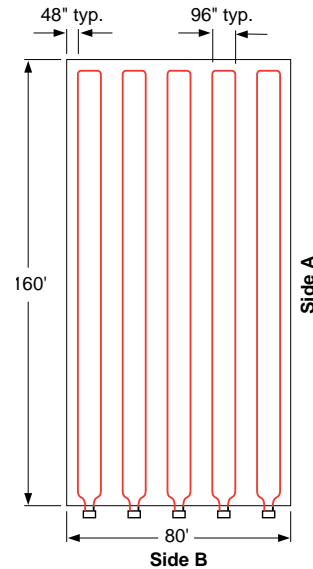

Figure 5.2. Hairpin layout

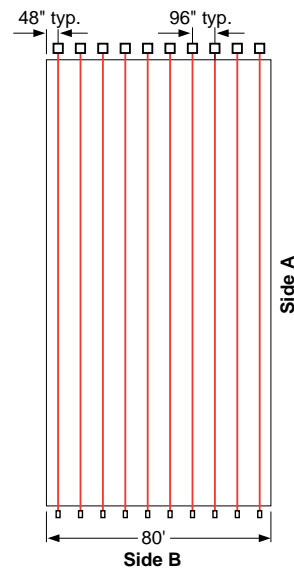

Figure 5.3. Straight run layout

### Lay Out Heating Cable

After determining the approximate total length of heating cable, the number of circuits, and the junction box location, do a trial layout. In making the trial layout, follow these recommendations:

- Start and end each circuit in a junction box. The power connection and end seal may be located in the same box or in different boxes.
- Do not design more than one run of heating cable per conduit.
- Arrange the conduit so it uniformly covers the area to be heated.
- Maintain the design conduit spacing within 4 inches.
- Do not extend the heating cable beyond the room or area in which it originates.
- Do not cross expansion, crack control, or other subfloor joints.
- Do not route the conduit closer than 4 inches to the edge of the subfloor, drains, anchors, or other material in the concrete.
- Do not exceed the maximum length of heating cable allowed on a branch circuit breaker as given in Table 5.3. The maximum length includes the heating cable covering the floor as well as the heating cable in the junction box and protective conduit.
- The maximum length of heating cable that can be pulled through conduit is 450 feet. The maximum total degree of conduit turn is 360 degrees.
- Do not install RaySol heating cable in ceilings or walls.
- When the combined lengths of two or more circuit runs are less than the maximum circuit length allowed, these runs can be combined in one circuit breaker.

## 5. Freezer Frost Heave Prevention

### Record Circuit Information

Reconstruct the trial circuit layout until the design meets all of the previous recommendations. Record the total length of heating cable used on each circuit. Assign each circuit to a circuit breaker in a specific panel board and record each circuit length.

Actual cable length per circuit (feet)

### 5.6 Electrical Design: Selecting and Sizing Electrical Parameters

#### Select Cable

Select the RaySol heating cable that matches your operating voltage:

- RaySol 1: 110–120 volts
- RaySol 2: 208–277 volts

Cable

#### Select Branch Circuit Breaker Size

Record the circuit breaker rating to be used.

Use ground-fault protection devices (GFPDs) for all RaySol applications.

Ground-fault protection devices with a 30-mA trip level are available from Westinghouse (GFEPD) and Square-D (QO-EPD). If operating at 277 volts, use a Raychem TraceGuard 277 GFPD.

**⚠ WARNING: To minimize the danger of fire from sustained electrical arcing if the heating cable is damaged or improperly installed, use a ground-fault protection device (GFPD) with a nominal 30-milliampere (mA) trip level. Arcing may not be stopped by conventional circuit breakers.**

Circuit breaker rating (amps)

#### Select Maximum Length of Heating Cable per Branch Circuit

Based on the layout and using the circuit breaker rating, select from Table 5.3 the maximum length of heating cable allowed on a branch circuit.

Maximum circuit length (feet)

#### Select Junction Box

For the heating cable power connection and end seal, select a UL Listed and CSA Certified junction box that is suitable for the location. Use a box with a minimum internal volume of 16 cubic inches if the box is metallic and 19 cubic inches if the box is not metallic.

The junction box containing the RaySol power connection and end seal must be accessible. According to the National Electrical Code, “accessible” is defined as 1) capable of being removed or exposed without damaging the building structure or finish, or 2) not permanently closed in by the structure or finish of the building. Refer to Article 370-19 of the National Electrical Code for restrictions on junction box location.

#### Size Transformer

Calculate the total transformer load as:

$$\text{Transformer load (W)} = 0.8 \times \text{Circuit breaker rating (A)} \times \frac{\text{Total cable length (ft)}}{\text{Maximum circuit length (ft)}} \times \text{Voltage}$$

Transformer load (watts)



## 5. Freezer Frost Heave Prevention

### Select Controls (optional)

Temperature controls are not normally used with the RaySol freezer-frost-heave-prevention system. The self-regulating heating cable automatically reduces its power output as the freezer subfloor temperature rises so that a thermostat is not necessary to provide high-temperature limit protection or to protect the heating cable. And since the heat output of the system is low, the energy savings realized by control of the subfloor temperature is small and often not worth the potential maintenance problems presented by use of temperature control devices.

For cases where temperature control or temperature monitoring is desired, use a thermostat with a remote sensing bulb similar to the Raychem AMC-1B. Locate the thermostat sensing bulb at the same elevation as the heating cable and midway between adjacent runs of cable. Keep the sensing bulb as far from the walls of the freezer as possible.

### 5.7 Example

This example is based on Figure 5.3 on page 27. It represents a freezer-floor frost-heave-prevention application where the freezer temperature is -20°F and the floor is insulated to R-40.

Heating cable spacing of 96 inches was selected from Table 5.2 on page 25. Twenty-four inches of heating cable per end was allowed for the component allowance, and 48 inches per end for the end allowance.

The estimated heating cable length was calculated as follows (based on the formula on page 26):

$$\text{Estimated heating cable length} = \frac{80 \text{ ft} \times 160 \text{ ft} \times 12}{96 \text{ in}} + 80 \text{ ft} + 40 \text{ ft} = 1720 \text{ ft}$$

After the layout was finalized, the actual length of heating cable used was 1730 feet in ten circuits, making the length of cable per circuit 173 feet.

The circuit breaker rating is 30 amps, the voltage is 277 Vac, and the maximum circuit length from Table 5.3 is 430 feet.

The transformer load per circuit was calculated as follows (based on the formula on page 28):

$$\text{Transformer load} = 0.8 \times 30 \text{ A} \times \frac{173 \text{ ft}}{430 \text{ ft}} \times 277 \text{ Vac} = 2675 \text{ W}$$



## 6. Condensed Specification Guide

This is the product portion of a specification for the RaySol System. For a complete specification that includes installation and testing recommendations, contact your Raychem representative.

### 6.1 Floor Warming and Heat Loss Replacement

#### PART 1 – GENERAL

- 1.1 Furnish and install a UL Listed and CSA Certified (select: concrete floor warming or heat loss replacement) system composed of RaySol heating cable, components, and controls.

#### PART 2 – PRODUCTS

- 2.1 The heating cable and termination components shall be UL Listed for Radiant Heating and CSA Certified for Designation 1B.
- 2.2 The self-regulating heating cables shall consist of two (2) nickel-copper bus wires embedded in parallel in a radiation-crosslinked polymer core that varies its power output in response to temperature all along its length, allowing the heating cable to be installed in conduit without overheating, to be cut to length in the field, and to have no heating-cable-to-cold-lead connections buried in the slab. The heating cable shall be covered with a radiation-crosslinked modified polyolefin dielectric jacket and protected by a tinned-copper braid and a fluoropolymer outer jacket. A constant-wattage-type heating cable is not acceptable.
- 2.3 The heating cable shall operate on (select: 110, 120, 208, 220, 240, or 277) volts without the use of transformers.
- 2.4 The heating cable shall be RaySol 1 or RaySol 2 as manufactured by Raychem Corporation.
- 2.5 The power connection, end seal, and splice kits shall be applied in the field.
- 2.6 Each circuit shall be protected by a 30-mA ground-fault protection device.

#### PART 3 – PERFORMANCE

- 3.1 The heating cable shall meet the following performance criteria:
  - For floor heat loss replacement: A minimum temperature of 70°F ( $\pm 5^\circ\text{F}$ ) or 2 watts/ft<sup>2</sup>.
  - For floor warming: A minimum temperature of 80°F ( $\pm 5^\circ\text{F}$ ) or 6 watts/ft<sup>2</sup>.
  - A maximum thermal output at 40°F of 16.5 watts/ft.
- 3.2 The heating cable spacing shall be determined by an application-specific, steady-state, finite-difference, thermal analysis of the floor to be warmed.
- 3.3 The program output shall show slab temperature based on the depth and thermal conductivities of the floor layers, ambient temperatures, voltage, and heating cable output. A copy of the program output shall be submitted to the engineer for approval.

#### PART 4 – INSTALLATION

- 4.1 The heating cable shall be installed according to the manufacturer's recommendations, the instructions supplied with the heating cable and components, and the instructions in the RaySol Installation Manual (H54693).
- 4.2 If in conduit, the heating cable shall be installed at least 1½ inches below the finished surface of the floor at the spacing indicated on the drawings.
- 4.3 The heating cable shall be protected from damage during installation. Heating cable repairs and splices shall be made using a splice kit provided by Raychem.

#### PART 5 – TESTING

- 5.1 After installation, prior to concrete pour, the cable shall be meggered at 2500 Vdc, from conductor to braid. Resistance readings shall be 20 megohms to infinity. After concrete pour, the cables shall be retested. Submit test record to the engineer.

## 6. Condensed Specification Guide

### 6.2 Tile and Marble Floor Warming

#### PART 1 – GENERAL

- 1.1 Furnish and install a UL Listed and CSA Certified tile and marble floor warming system composed of RaySol heating cable, components, and controls.

#### PART 2 – PRODUCTS

- 2.1 The heating cable and termination components shall be UL Listed for Radiant Heating and CSA Certified for Designation 1B.
- 2.2 The self-regulating heating cables shall consist of two (2) nickel-copper bus wires embedded in parallel in a radiation-crosslinked polymer core that varies its power output in response to temperature all along its length, allowing the heating cable to be installed in conduit without overheating, to be cut to length in the field, and to have no heating-cable-to-cold-lead connections buried in the slab. The heating cable shall be covered with a radiation-crosslinked modified-polyolefin dielectric jacket and protected by a tinned-copper braid and a fluoropolymer outer jacket. A constant-wattage-type heating cable is not acceptable.
- 2.3 The heating cable shall operate on (select: 110 or 120) volts without the use of transformers.
- 2.4 The heating cable shall be RaySol 1 as manufactured by Raychem Corporation.
- 2.5 The power connection, end seal, and splice kits shall be applied in the field.
- 2.6 Each circuit shall be protected by a 5-mA sensitivity ground-fault protection device.

#### PART 3 – PERFORMANCE

- 3.1 The heating cable shall meet the following performance criteria:
  - The floor temperature shall be maintained above 80°F.
  - The maximum thermal output at 40°F shall be 16.5 watts/ft.
- 3.2 Heating cable spacing shall be determined by an application-specific, steady-state, finite-difference, thermal analysis of the floor to be warmed.
- 3.3 The program output shall show slab temperature based on the depth and thermal conductivities of the floor layers, ambient temperatures, voltage, and heating cable output. A copy of the program output shall be submitted to the engineer for approval.

#### PART 4 – INSTALLATION

- 4.1 The heating cable shall be installed according to the manufacturer's recommendations, the instructions supplied with the heating cable and components, and the instructions in the RaySol Installation Manual (H54693).
- 4.2 The heating cable shall be protected from the setting bed to the junction box by installing it inside 1/2-inch-minimum EMT conduit or rigid plastic or metal conduit.
- 4.3 The protective conduit shall be extended at least 6 inches into the setting bed. Install bushings on both ends of the conduit.
- 4.4 The heating cable shall be protected from damage during installation. Heating cable repairs and splices shall be made using only approved splice kits provided by Raychem.

#### PART 5 – TESTING

- 5.1 After installation of the heating cable, prior to placing the mortar setting bed, the heating cable shall be meggered at 2500 Vdc, from conductor to braid. Resistance readings shall be 20 megohms or greater. After placing the setting bed, the cables shall be retested. Do not install tile or marble over heating cables that fail the Megger test. After the floor is complete, repeat the test and submit test records to the engineer. Do not energize heating cables with Megger readings of less than 20 megohms.

## 6. Condensed Specification Guide

### 6.3 Freezer Frost Heave Prevention

#### PART 1 – GENERAL

- 1.1 Furnish and install a UL Listed and CSA Certified freezer-frost-heave-prevention system composed of RaySol heating cable, components, and controls.

#### PART 2 – PRODUCTS

- 2.1 The heating cable and termination components shall be UL Listed for Radiant Heating and CSA Certified for Designation 1B.
- 2.2 The self-regulating heating cables shall consist of two (2) nickel-copper bus wires embedded in parallel in a radiation-crosslinked polymer core that varies its power output in response to temperature all along its length, allowing the heating cable to be installed in conduit without overheating, to be cut to length in the field, and to have no heating-cable-to-cold-lead connections buried in the floor. The heating cable shall be covered with a radiation-crosslinked modified-polyolefin dielectric jacket and protected by a tinned-copper braid and a fluoropolymer outer jacket. A constant-wattage-type heating cable is not acceptable.
- 2.3 The heating cable shall operate on (select: 110, 120, 208, 220, 240, or 277) volts without the use of transformers.
- 2.4 The heating cable shall be RaySol 1 or RaySol 2 as manufactured by Raychem Corporation.
- 2.5 The power connection and end seal shall be applied in the field.
- 2.6 Each circuit shall be protected by a 30-mA ground-fault protection device.

#### PART 3 – PERFORMANCE

- 3.1 The heating cable shall meet the following performance criteria:
  - The subfloor temperature at the coldest section in contact with either sand or soil shall be 40°F, with the freezer load (cooling load imposed on the system by the frost heave prevention) ranging between but not exceeding 0.3 to 2.3 watts/ft<sup>2</sup> depending on the R-factor of the floor insulation and cable spacing.
- 3.2 Heating cable spacing shall be determined by an application-specific, steady-state, finite-difference, thermal analysis of the floor to be warmed.
- 3.3 The program output shall show slab temperature based on the depth and thermal conductivities of the floor layers, ambient temperatures, voltage, and heating cable output. A copy of the program output shall be submitted to the engineer for approval.

#### PART 4 – INSTALLATION

- 4.1 The heating cable shall be installed according to the manufacturer's recommendations, the instructions supplied with the heating cable and components, and the instructions in the RaySol Installation Manual (H54693).
- 4.2 The heating cable shall be installed in conduit according to the manufacturer's instructions.
- 4.3 The conduit shall be extended to the junction box. Do not use wire pulling compound. No splices within the conduit are allowed.

#### PART 5 – TESTING

- 5.1 After installation, prior to concrete pour, the heating cable shall be meggered at 2500 Vdc, from conductor to braid. Resistance readings shall be 20 megohms to infinity. After concrete pour, the cables shall be retested. Submit test record to the engineer.



### Warranty; Suitability

(a) Raychem warrants products delivered hereunder against faulty workmanship and use of defective materials for a period of eighteen (18) months from the date of installation or twenty-four (24) months from the date of shipment, whichever is sooner. When the contract calls for systems design, drawings, technical advice, services or instructions (collectively "Services") by Raychem, in connection with the products, Raychem further warrants for the above stated warranty period solely that such Services will be undertaken in accordance with Raychem's reasonable technical judgment based on Raychem's understanding of the pertinent technical data as of the date of performance of such Services. The foregoing warranty with respect to products shall not be enlarged or affected by, and (except as expressly provided herein) no obligation or liability shall arise or grow out of, Raychem's rendering Services in connection with the products. Such warranty is the only warranty made by Raychem and it can be amended only by a written instrument signed by a duly authorized officer of Raychem. If the products furnished by Raychem hereunder are determined to contain a deficiency, Buyer's exclusive remedy shall be to have Raychem repair such products or supply replacement products or credit Buyer's account for such products and accept their return, whichever Raychem may elect in its sole discretion. Notwithstanding the foregoing sentence, in no circumstances shall Raychem have any liability or obligation with respect to expenses, liabilities, or losses associated with the installation or removal of any products or the installation of replacement products or for any inspection, testing, or redesign occasioned by any deficiency or by the repair or replacement of products. Raychem's obligations are subject to the further condition that Raychem shall have no liability whatsoever for any deficiency unless (i) Raychem is notified in writing promptly (and in no event later than 30 days) after discovery by Buyer of the alleged deficiency, which notice shall include a detailed explanation of the alleged deficiency, (ii) the products containing the alleged deficiency are promptly returned to Raychem, F.O.B. Raychem's plant, and (iii) Raychem's examination of such products discloses to Raychem's satisfaction that such alleged deficiency actually exists and occurred in the course of proper and normal use and was not caused by accident, misuse, neglect, alteration, or improper installation, repair, or testing. If any products so prove to contain a deficiency and Raychem elects to repair or replace them, Raychem shall have a reasonable time to make such repair or replacement.

THE FOREGOING WARRANTY IS IN LIEU OF ALL OTHER WARRANTIES, EXPRESS OR IMPLIED, INCLUDING WITHOUT LIMITATION ANY IMPLIED WARRANTY OF MERCHANTABILITY, FITNESS FOR A PARTICULAR PURPOSE, OR NON-INFRINGEMENT, AND OF ANY OTHER OBLIGATION ON THE PART OF RAYCHEM.

(b) It shall be the responsibility of the Buyer to determine, on the basis of the most current written technical data, the suitability of the products and of any systems design or drawings for the intended use and their compliance with applicable laws, regulations, codes, and standards and the Buyer assumes all risks pertaining thereto.

*RaySol and TraceGuard 277 are trademarks of Raychem Corporation.  
Raychem is a registered trademark of Raychem Corporation.*



LISTED

9J86  
Radiant  
Heating Cable



DESIG. 1B

*All of the above information, including illustrations, is believed to be reliable. Users, however, should independently evaluate the suitability of each product for their application. Raychem makes no warranties as to the accuracy or completeness of the information, and disclaims any liability regarding its use. Raychem's only obligations are those in the Standard Terms and Conditions of Sale for this product, and in no case will Raychem be liable for any incidental, indirect, or consequential damages arising from the sale, resale, use, or misuse of the product. Specifications are subject to change without notice. In addition, Raychem reserves the right to make changes—without notification to Buyer—to materials or processing that do not affect compliance with any applicable specification.*

**Raychem Corporation**  
**Construction Products Group**  
300 Constitution Drive  
Menlo Park, California 94025-1164  
Tel (800) 542-8936  
Fax (650) 361-5579

**Raychem Canada Ltd.**  
6303 Airport Road  
Mississauga, Ontario  
Canada L4V 1N4  
Tel (800) 387-3993  
Fax (905) 671-0972

