

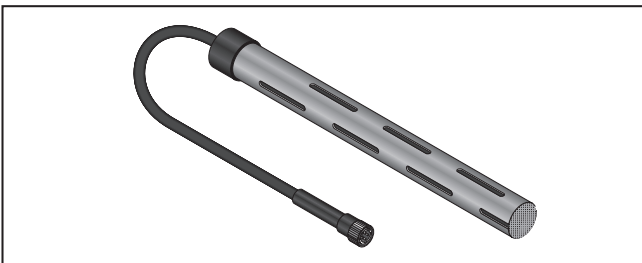

## RAYCHEM TraceTek

# TT-FFS FAST FUEL DETECTION PROBE

## Care And Cleaning Instructions



### DESCRIPTION

Use these instructions when a nVent RAYCHEM TraceTek TT-FFS probe has been exposed to dirt, mud, sand and after leak detection events with heavier fuels such as jet fuel, diesel or fuel oil.

### CAUTION:

Potential electrostatic discharge hazard –  
Do not rub with a dry cloth.

1

#### Test the TT-FFS Probe

- Determine the condition of TT-FFS probe sensor blade coating.
- Use the TT-FFS Probe Tester to determine the current condition of the TT-FFS Probe. Refer to TT-FFS Probe Tester Operating Instructions document H58496 for testing procedure details
- Possible TT-FFS Probe conditions include:
  - Probe in Alarm- signified by LED single flash each second after TT-FFS Probe initially connected.
  - Probe is Damaged (internal wire damage or connector damage)- signified by no LED flashing when TT-FFS Probe initially connected, and no LED single flash each second after red test button is pushed.
  - Probe is Good- signified by no LED flashing when TT-FFS Probe initially connected, but LED single flash each second after red test button is pushed.
- If TT-FFS Probe condition is Good, there is no need for cleaning procedure unless desired for cosmetic reasons.
- If TT-FFS Probe condition is Damaged, probe should be replaced due to damage. Cleaning procedures will not fix the damage.
- If TT-FFS Probe condition is in Alarm, cleaning procedures can be implemented to achieve reset, which may recreate the Good condition.

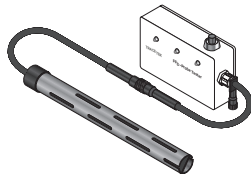

2

#### Inspect the sensor blade coating

- If the Extreme Environment Cover (EEC) has been installed on TT-FFS Probe, remove it carefully before performing inspection. Refer to TT-FFS EEC Installation Instructions document H58519.
- Visually inspect the sensor blade coating, but do not touch it. A flashlight may be useful to shine through the steel screen and through openings in the side of the orange tube to help see the sensor blade coating. A sensor blade in good condition will have a uniform gray or black coating like the photo on the right, and may be able to reset to Good condition with cleaning procedures.
- A sensor with a scratched or damaged film like that in the picture on the right may need to be replaced. Cleaning procedures may be attempted, but are unlikely to result in a reset to Good condition.
- **(Note:** Protective steel screen has been removed for clarity in these photos).
- If contamination (dirt, mud, sand) prevents visual inspection of the sensor blade coating, then proceed with water cleaning step.

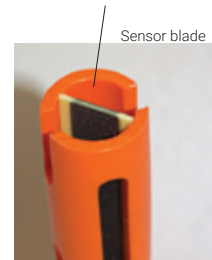

3

### Clean with Water

- Do not remove the protective steel mesh screen at the bottom end of the TT-FFS probe. Place sufficient water in a small container and soak the full length of the TT-FFS probe for 15 minutes. Maximum fluid level is ½ inch below black cap. Make sure TT-FFS probe wiring stays high and dry.
- DO NOT SHAKE OR STIR! If physical contamination like dirt, mud or sand is present-care must be taken to avoid degrading the sensor blade coating. Very gentle cleaning of exterior orange surface of TT-FFS probe can be performed, taking care not to push contamination through the openings in the orange tube and onto the sensor blade coating.
- Do not use compressed or heated air. If contamination is still present inside the orange tube and on surface of sensor blade coating, then you must be very careful to avoid damaging the coating. Do not use tools to remove contamination.
- After soaking in water, let dry in air for 20 minutes.

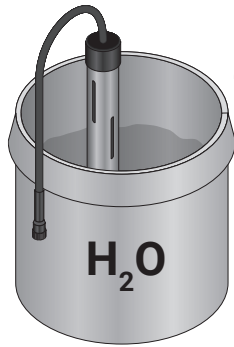

4

### Retest the TT-FFS Probe

- Retest TT-FFS Probe condition to see if it has changed. If Alarm condition has been reset to Good condition, then further cleaning steps are not recommended. If Alarm condition still exists, re-inspect sensor blade coating for possible damage.

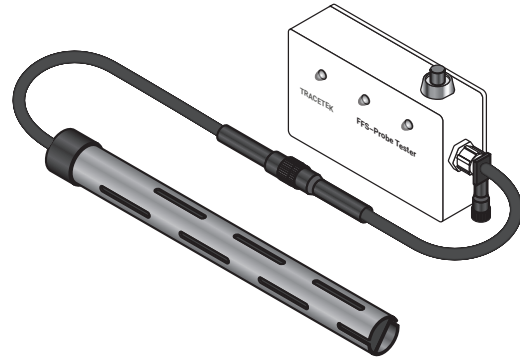

5

### Clean with isopropyl alcohol and retest

- If the TT-FFS Probe is still in Alarm condition, or visual inspection of the sensor blade coating suggests possible contamination with an oily material, then perform the isopropyl alcohol cleaning procedure to potentially achieve reset.
- Place sufficient isopropyl alcohol in a small container and soak the full length of the TT-FFS probe for 10 minutes. Maximum fluid level is ½ inch below black cap. Make sure TT-FFS probe wiring stays high and dry.
- DO NOT SHAKE OR STIR! The sensor blade coating is extremely fragile when soaking in isopropyl alcohol. The idea is to dilute any fuel trapped in the sensor blade coating without damaging the thin sensor blade coating.
- Do not use compressed or heated air.
- After soaking in isopropyl alcohol, let dry in air for 1 hour.
- Retest TT-FFS Probe condition to see if it has been reset from Alarm condition to Good.
- If the TT-FFS Probe has not reset after 1st isopropyl alcohol cleaning cycle, you can try up to 3 cycles total of isopropyl alcohol cleaning, taking care to use fresh solution of isopropyl alcohol in each cleaning cycle.



6

### Clean with Naptha and retest

- If the TT-FFS Probe is still in Alarm condition after up to 3 cycles of isopropyl alcohol cleaning, then perform the naphtha cleaning procedure to potentially achieve reset.
- Place sufficient naphtha in a small container and soak the full length of the TT-FFS probe for 10 minutes. Maximum fluid level is ½ inch below black cap. Make sure TT-FFS probe wiring stays high and dry.
- DO NOT SHAKE OR STIR! The sensor blade coating is extremely fragile when soaking in naphtha. The idea is to dilute any heavy oil trapped in the sensor blade coating without damaging the thin sensor blade coating.
- Do not use compressed or heated air.
- After soaking in naphtha, let dry in air for 1 hour.
- Retest TT-FFS Probe condition to see if it has been reset from Alarm condition to Good.
- If the TT-FFS Probe has not reset after 1st naphtha cleaning cycle, you can try one additional cycle of isopropyl alcohol cleaning to remove excess naphtha from the sensor blade coating. Retest TT-FFS Probe condition to see if it has been reset from Alarm condition to Good. If the TT-FFS Probe is still in Alarm condition, it cannot be reset with cleaning procedures, and needs to be replaced.



7

### Reinstall Extreme Environment Cover

- If TT-FFS Probe has been reset from Alarm condition to Good, the TT-FFS Probe is ready for re-use. Install Extreme Environment Cover (EEC) if removed in step 2. Refer to TT-FFS EEC Installation Instructions document H58519.

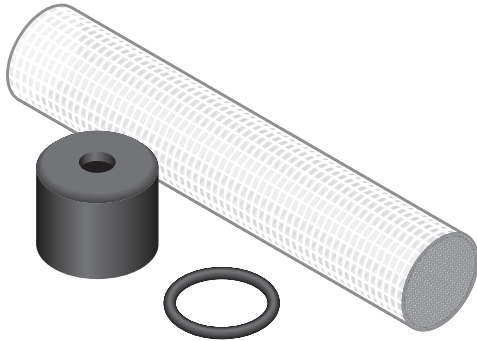

**TT-FFS-EEC-100**



**North America**

Tel +1 800 545 6258  
Fax +1 800 527 5703  
thermal.info@nvent.com

**Europe, Middle East, Africa**

Tel +32 16 213 511  
Fax +32 16 213 604  
thermal.info@nvent.com

**Asia Pacific**

Tel +86 21 2412 1688  
Fax +86 21 5426 3167  
cn.thermal.info@nvent.com

**Latin America**

Tel +1 713 868 4800  
Fax +1 713 868 2333  
thermal.info@nvent.com



[nVent.com](http://nVent.com)

©2018 nVent. All nVent marks and logos are owned or licensed by nVent Services GmbH or its affiliates. All other trademarks are the property of their respective owners.  
nVent reserves the right to change specifications without notice.

RaychemTraceTek-IM-H58307-TTFFS-EN-1805