



TRACETEK

TT-JC-CK-PC-M/F

TT-JC-CK-PC-M/F-100

Field installed connectors for nVent RAYCHEM TraceTek TT-JC bulk jumper cable
Installation Instructions



KIT CONTENTS

TT-1000/JC-CK-PC -M/F (PN P00000080)
(10 M and 10 F connectors)

Item	Qty	Description
A	10	TT-CK-PC-F socket connector
B	10	TT-CK-PC-M pin connector
C	10	Silicone washer
D	20	Heat-shrinkable tubing, labeled SCT
E	85	SolderSleeve® splices (5 extras)

TT-1000/JC-CK-PC -M/F-100 (PN 269496-000)
(100 M and 100 F connectors)

Item	Qty	Description
A	100	TT-CK-PC-F socket connector
B	100	TT-CK-PC-M pin connector
C	100	Silicone washer
D	200	Heat-shrinkable tubing, labeled SCT
E	850	SolderSleeve splices (50 extra)

DESCRIPTION

These instructions describe field connecting of nVent RAYCHEM TraceTek TT-JC Bulk Jumper Cable.

For technical support call nVent at (800) 545-6258.

TOOLS REQUIRED

- Razor blade or utility knife
- TT-ULTRA-TORCH (PN 390067-000) flameless heating tool (Ultratorch 200) or suitable heat gun with concentrator tip.
- High impedance ohmmeter (Fluke 87 or equivalent; meter must be capable of measuring to at least 20 megohm)
- Needle nose pliers
- Small wire cutters
- TT-MET-PC (PN 169905-000)

NOTES

- Do not use an open flame heating tool.
- Jumper cable ends are different, and require a specific connector type at each end. Check the cable end before installation to ensure proper wire orientation as shown in step 5.
- In TraceTek leak detection systems, the socket connector end of jumper cable is oriented away from the alarm module- while the pin connector end is oriented towards the alarm module. If a jumper cable is to be connected directly to the alarm module, a pin connector is not used.

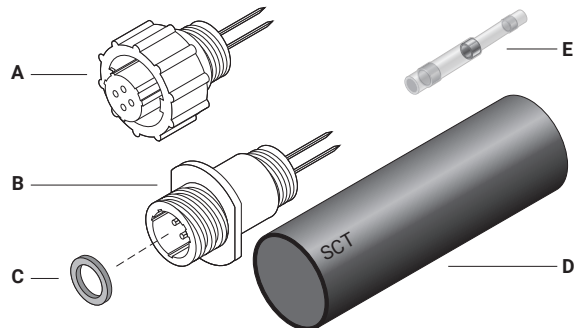

WARNING:

FIRE HAZARD: Heat guns and flameless heating tools can cause fire or explosion in hazardous areas. Be sure there are no flammable materials or vapors in the area before using these tools. Follow all site safety guidelines when working in hazardous areas.

Component approvals and performance are based on the use of specified parts only.

CAUTION:

HEALTH HAZARD: Overheating heat-shrinkable tubing or SolderSleeves will produce fumes that may cause irritation. Use adequate ventilation and avoid charring or burning. Consult MSDS RAY3122 and RAY5103 for further information.

CHEMTREC 24-hour emergency telephone: (800) 424-9300

Non-emergency health and safety information: (800) 545-6258.

1

- Slide SCT tube onto the cable end.
- Use the razor to lightly score the clear plastic cable jacket all the way around 1 inch (25 mm) from the end.
- **Do not cut through the jacket.**

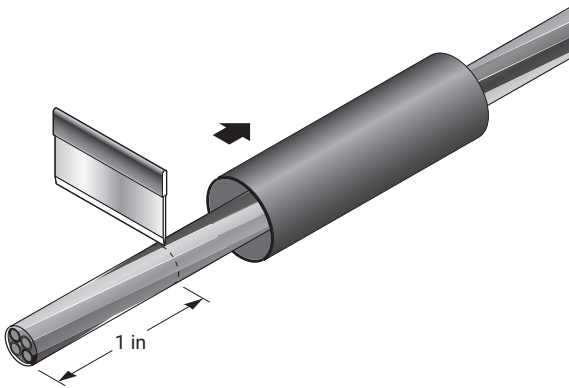

2

- Bend the jacket back and forth to break free the scored section.
- Remove the scored section of the jacket.

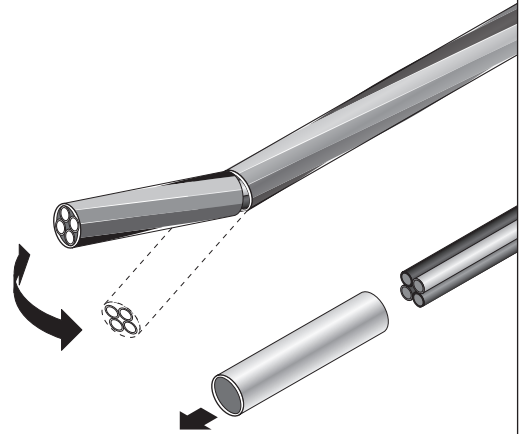

3

- Flare the 4 wires apart to accommodate the wire stripper jaws.
- Use the 18 AWG slot of the wire stripper to strip 1/2 inch (13 mm) of insulation from each wire.
- For short jumper cable sections, be careful not to pull wires out of jacket.
- If any of the wire strands have separated, re-twist the strands to form a tight bundle. Stray strands can damage SolderSleeves and cause shorts.

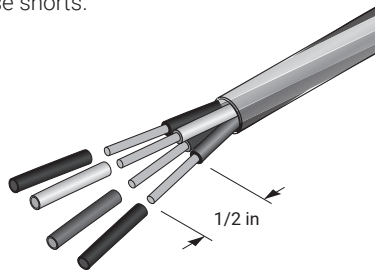

4

- Use the ohmmeter to measure the resistance between each combination of 2 wires.
- The resistance between any 2 wires must be greater than 20 megohm (meter may read: ∞, O.L., etc.).
- If lower resistance is found, check the opposite cable end to see if the wire tips are touching.
- Replace the jumper cable if necessary.

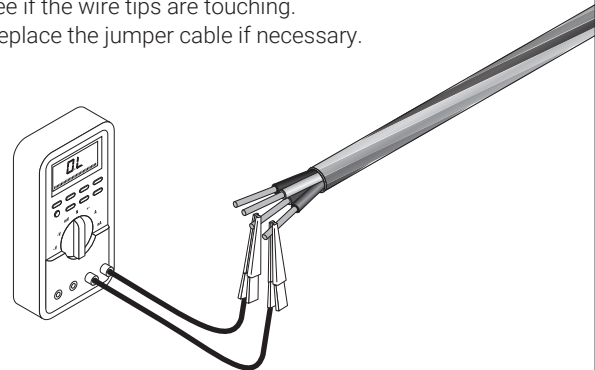

5

Install the Connector:

- View the jumper cable from the end and arrange the wires as shown.

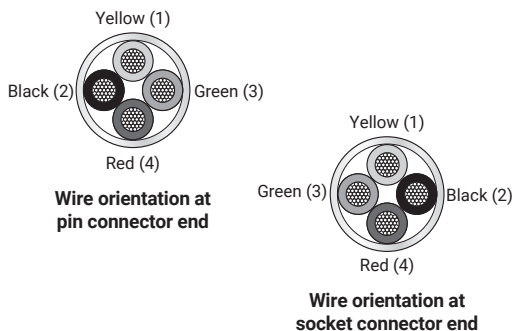

6

- Keep wires in the same order that they exit from the cable end.
- Slide a SolderSleeve splice (small end first) onto each wire, all the way to the cable end.
- The solder ring must lie over bare conductor, not insulation.
- Wire ends must extend beyond the solder rings.

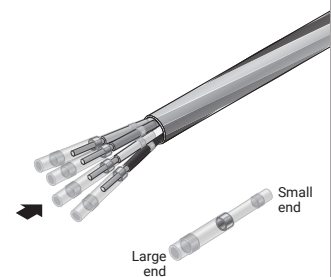

7

Align the Connector

- Examine the mating end of the connectors. The large plastic tab (socket connector) or the large key way (pin connector) corresponds to the yellow wire. Each pin/ socket position is numbered on the front and back of the connector body. Once the yellow wire is aligned check that the other wires are also correctly aligned.

Pin Connector (Part B)

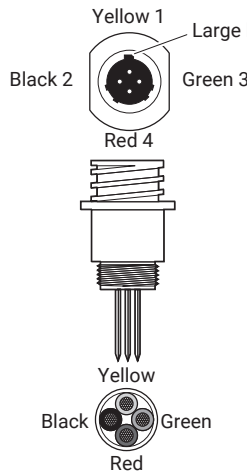

Socket Connector (Part A)

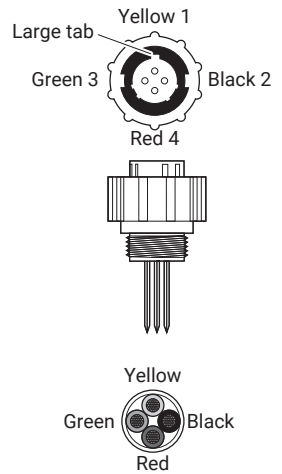

8

- Insert TT-MET-PC to use as a holder while applying heat. (For pin connector use a socket connector as a holder).
- Make sure the wires are arranged as shown in previous step.
- Orient assembly vertically.
- Orient the connector and push the aligned connector into the solder sleeves until fully seated.
- Check that wire strands are not kinked and solder rings are centered over posts and bare wires.

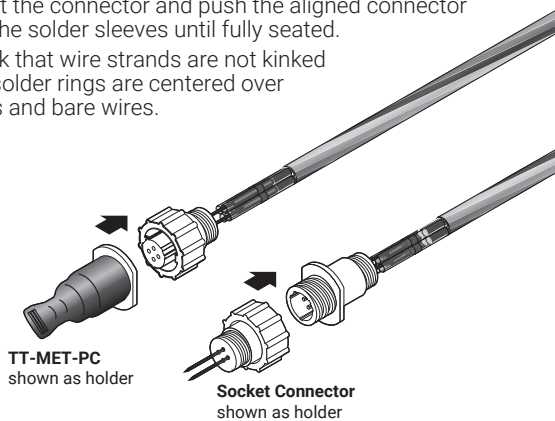

9

- Heat the SolderSleeves until they have shrunk completely and the solder rings have melted and flowed. **Keep the heat source moving to avoid charring connector.**

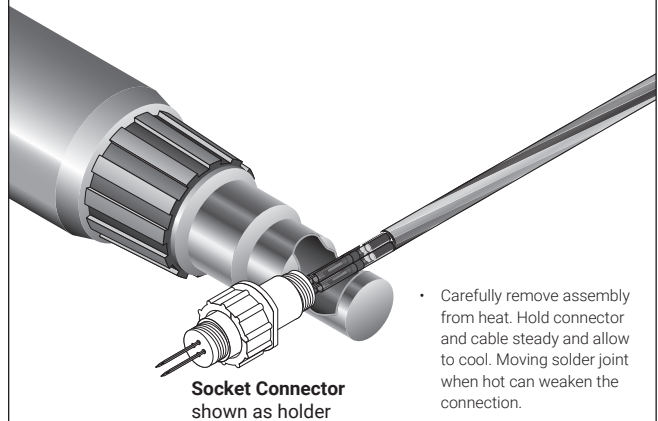

10

- Push SCT tube to the flange section of either connector type.

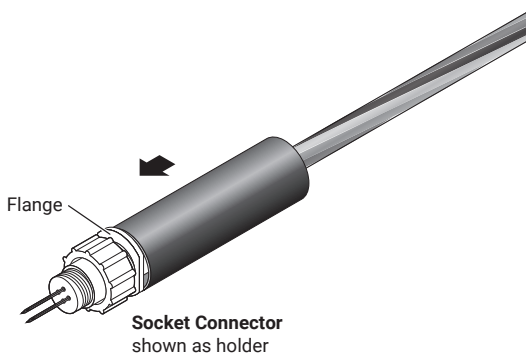

11

- Heat shrink approximately 1/4 inch (6 mm) of the SCT tube onto the connector. For both connector types, heat only until the tube is recovered and smooth.
- **Do not overheat. The tube will slip off of the connector if it is overheated.**
- Allow to cool before proceeding.

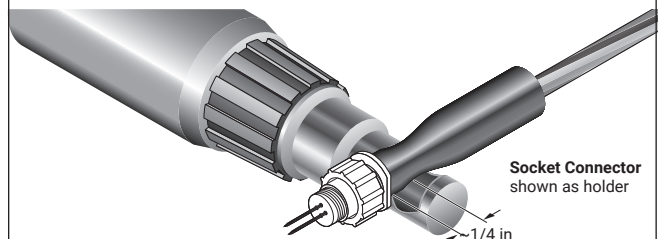

- Heat shrink the rest of the tube, avoiding the already shrunk section.
- While the tube is still hot, inspect the exposed adhesive at the tubing/cable interface.
- If a void is visible, use a glove or rag to squeeze the tube slightly and fill the void with molten adhesive.

⚠ CAUTION: Burn Hazard. Do not get hot adhesive on your bare skin. The hot adhesive will burn your skin.

- If the tubing has moved more than 1/8 inch (3 mm) off the threaded connector, push the hot tubing back to original position. Push using the "holder" connector. Do not push using the cable, as this could weaken the solder joint connections.
- After SCT tubing cools, remove the "holder" connector and for the pin connector, insert the silicone washer.

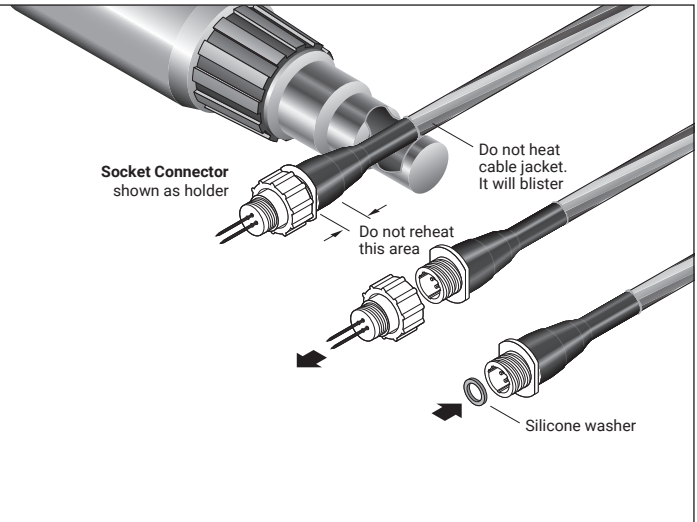

Test the Connector Assembly

Electrical Test

- Attach the mating connector with posts to the connector to be tested.
- If both cable ends have connectors, attach a mating end termination at the opposite end. If there is no connector on the opposite cable end, prepare it according to steps 1 thru 3. Then twist together wires 1 & 2 and wires 3 & 4.
- Use an ohmmeter to measure the resistance between the connector posts.
- The resistance between post 1 & 2, or 3 & 4 should be about 15Ω per 1000 feet (303 m) of cable length (i.e. a 100 ft. (30 m) cable should measure approximately 1.5Ω between the posts).
- The resistance between post 2 and 3 should be greater than 20 megohms.
- If the assembly fails any of the resistance tests;
 - 1) Check that the wires are not touching at the opposite cable end, if not connectorized.
 - 2) If necessary, cut off and discard the connector and install a new one.

Note: Do not leave connector open to environment. If the connector becomes wet or contaminated, it will need to be replaced.

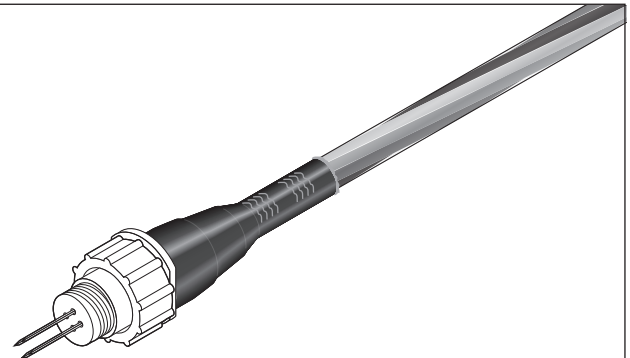

Wire orientation at cable end opposite socket connector

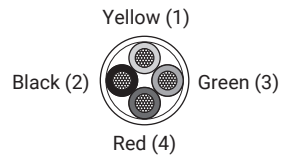

Wire orientation at cable end opposite pin connector

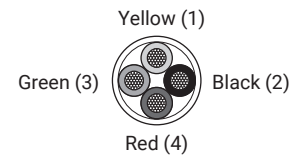

North America

Tel +1.800.545.6258
Fax +1.800.527.5703
thermal.info@nvent.com

Europe, Middle East, Africa

Tel +32.16.213.511
Fax +32.16.213.604
thermal.info@nvent.com

Asia Pacific

Tel +86.21.2412.1688
Fax +86.21.5426.3167
cn.thermal.info@nvent.com

Latin America

Tel +1.713.868.4800
Fax +1.713.868.2333
thermal.info@nvent.com



nVent.com