

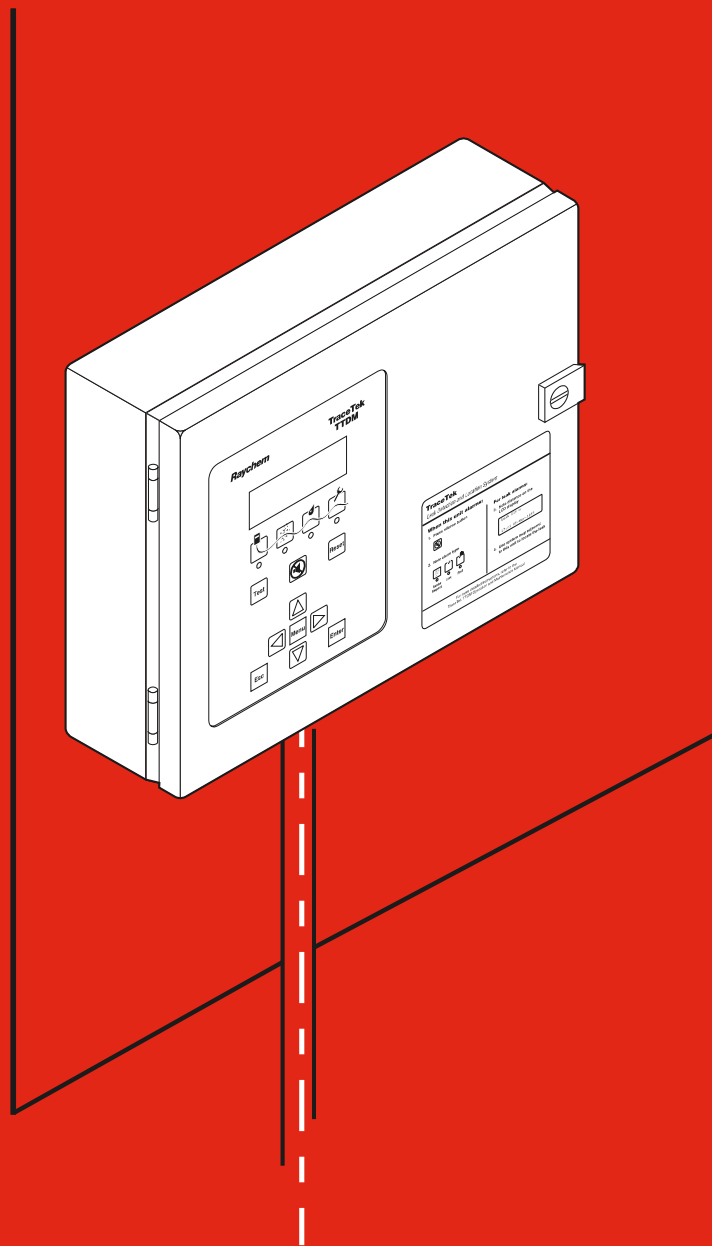

Design Guide for  
Double Containment  
Pipes and Tanks

# TraceTek® Leak Detection and Location Systems



C  
H  
E  
M  
E  
L  
E  
X®

# Table of Contents

---

1. How To Use This Guide	2
Overview of Sections	3
<hr/>	
2. TraceTek System Description	4
Overview of Technical Capabilities	6
<hr/>	
3. General Project Considerations	7
<hr/>	
4. Overview of Key Design Parameters	8
<hr/>	
5. Mechanical Design/Installation Requirements	10
Clearance	10
Pipe Sizing	11
Multiple Pipes	11
Centralizers	11
Fittings	12
Containment Access	12
Pull Rope	14
Low-Point Drains	15
Sealing of the Containment Pipe	16
Mechanical Contractor's Hand-off Requirements	16
Mechanical Specification Supplement	17
<hr/>	
6. Electrical Design/Installation Requirements	19
Power Requirements	19
Hookup Requirements	19
TraceTek Leak Detection Installation	20
Performing the Acceptance Testing	22
Purging the Containment Pipe	23
Preparing a System Map	23
Commissioning the System	23
Electrical Specification Supplement	24
<hr/>	
7. Summary of Contractor Responsibilities	26
Mechanical Contractor's Responsibilities	26
Electrical Contractor's Responsibilities	26
<hr/>	
8. System Descriptions for Other Applications	27
Double-Contained Tanks	28
Pipe and Tank Combinations	30
Trenches/Sumps	32
<hr/>	
Tables	
1. Suggested Pipe Sizing	11
2. Containment Access Requirements	12
3. Product Selection Matrix	27

# 1. How to Use This Guide

---

This TraceTek Design Guide will assist engineers involved in the design of double containment piping for use with cable-type leak detection systems. Although the guide focuses on double containment pipe applications, it also touches on other double containment applications. In addition, it provides instructions for all engineering disciplines involved in the design of a TraceTek leak detection system.

To facilitate proper installation and improve reliability, the engineer should specify the leak detection system as part of the electrical or instrumentation portion of the specification. Alternatively, the engineer should provide a separate section for leak detection in the specification

For clarity, this guide treats the mechanical and electrical requirements for designing the TraceTek system in two separate sections. Forming the core of these two sections are two sets of supplemental specifications:

- Mechanical specifications for piping design and installation.
- Electrical specifications for leak detection installation in the piping system.

## **Mechanical Specifications**

The mechanical specifications cover the mechanical requirements for double containment piping to be used with cable-type leak detection systems. These mechanical specifications:

- Supplement the “Division 15:Mechanical” section of the specification for double containment piping that will be monitored by a cable-type leak detection system.
- Ensure that the piping system is cable ready.
- Must be included in the Division 15 section of the specification.

## **Electrical Specifications**

The electrical specifications cover the electrical requirements for the cable-type leak detection system when it is used in double containment piping. These electrical specifications:

- Supplement the “Division 16: Electrical” section of the specification for double containment piping that will be monitored by a cable-type leak detection system.
- Provide guidance for the electrical design and installation of the leak detection system.
- Must be included in the Division 16 section of the specification.

---

## *Overview of Sections*

The following is an outline of the remaining sections in this guide:

- TraceTek System Description provides an overview of the TraceTek leak detection system and its features.
- General Project Considerations suggests questions that must be considered when deciding on a leak detection approach.
- Overview of Key Design Parameters outlines the elements of the TraceTek system.
- Mechanical Design/Installation Requirements explains the piping system requirements in detail, and includes the supplemental mechanical specifications for cable-type leak detection that must be incorporated in the double containment pipe specification.
- Electrical Design/Installation Requirements explains the electrical requirements for cable-type leak detection systems, and includes the supplemental electrical specifications that must be incorporated in the specification.
- Summary of Contractor Responsibilities outlines the responsibilities of both mechanical and electrical contractors who are involved in or can affect the installation of cable-type leak detection systems.
- System Descriptions for Other Applications offers a brief discussion of double containment applications other than piping and provides a matrix of system capabilities and applications that will help in the selection of products for other applications.

## 2. TraceTek System Description

The TraceTek system for double-wall piping continuously monitors piping for liquid leaks all along the length of the sensing cable. In the event of a leak, the cable senses the presence of the fluid and activates an alarm and locator module. The module sounds an alarm and indicates on a digital display the distance to the leak. The system map installed next to the alarm module is used to pinpoint the leak location.

The module also sounds an alarm should there be any loss of system integrity.

The TraceTek system, therefore, is both an alarm system and a leak location system.

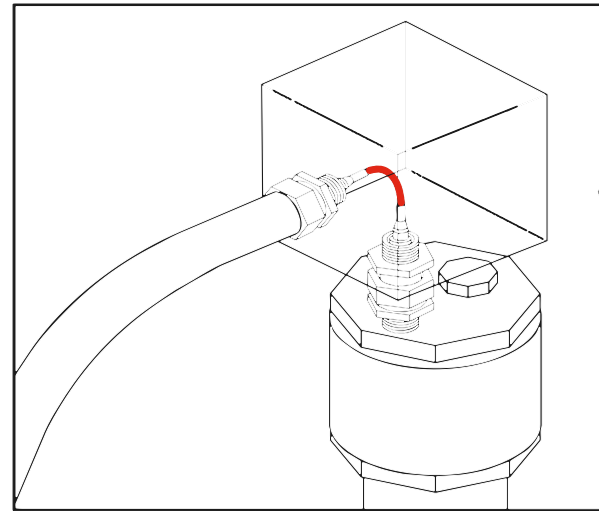

Tank cap assembly

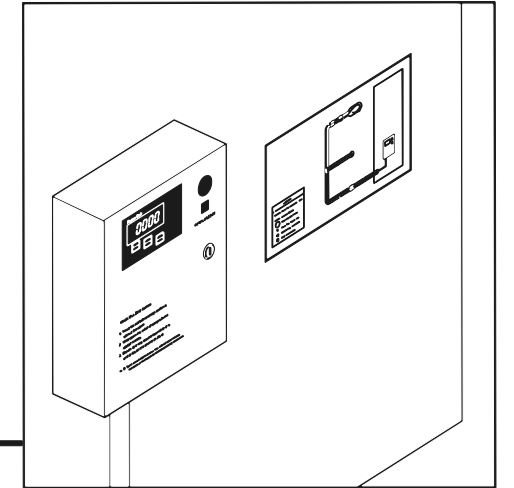
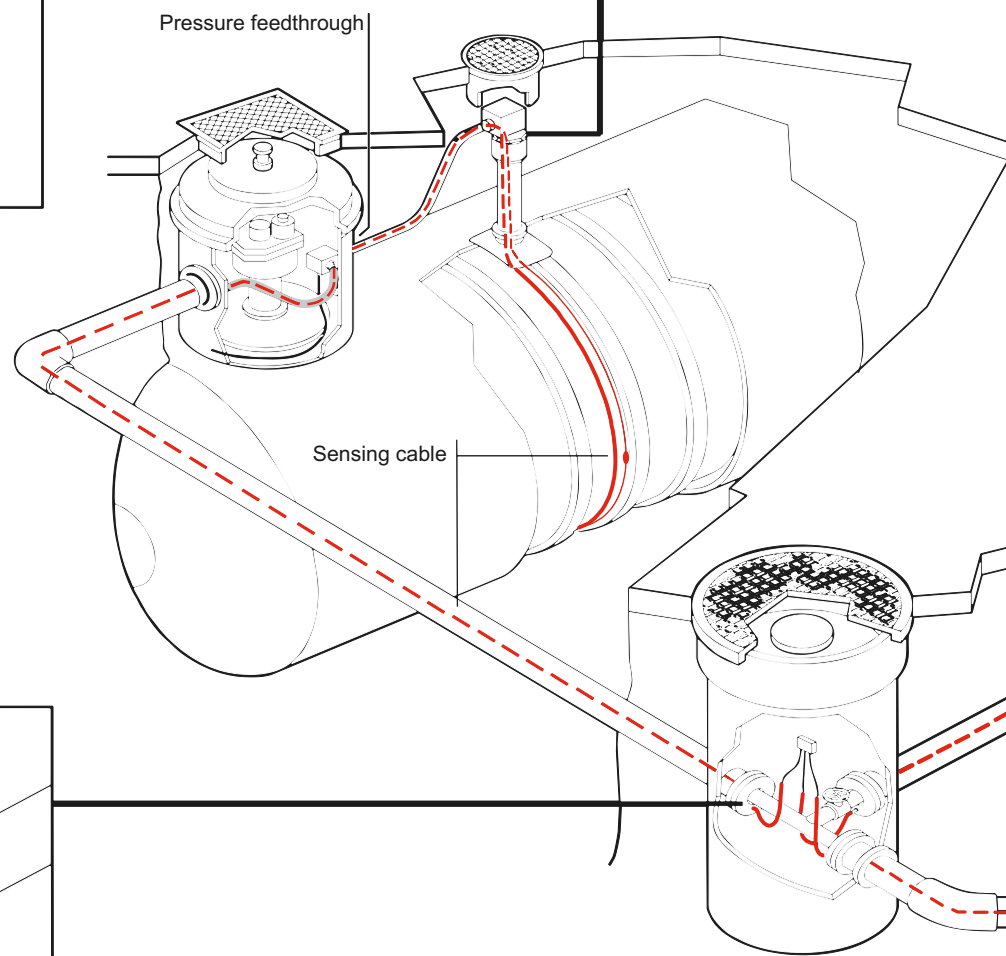

Alarm and locator module with system map

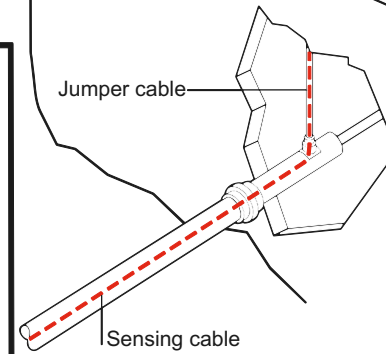

Jumper cable

Sensing cable

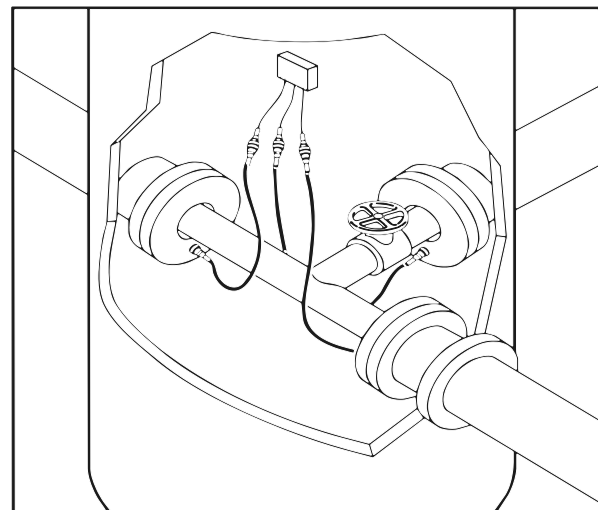

Branching connector

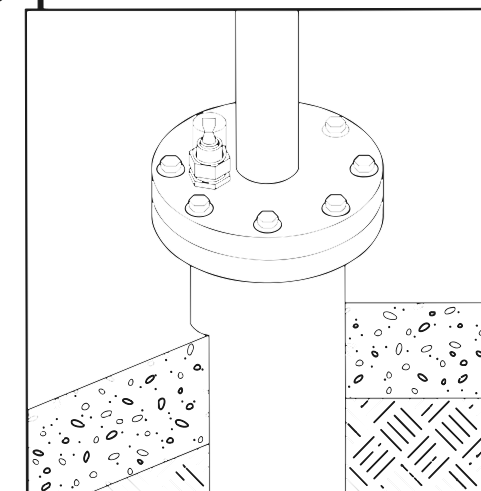

Modular end termination

---

## Overview of Technical Capabilities

### Alarm and Locator Module

The TraceTek alarm module provides both a visual and audible warning if there is either a leak or a loss of system integrity.

- The alarm module is available with a display that indicates, either in feet or in meters, the distance to a leak.
- One TraceTek alarm module monitors up to 2000 feet or 1000 meters of sensing cable.
- A single-pole-double-throw (SPDT) relay is a standard feature in the module.
- A current transmitter with 4- to 20-mA output is available to link location data to host computers.
- Custom panels containing multiple alarm modules are available to monitor long distances or complex systems.

### Sensing Cable

The TraceTek sensing cable is installed in the containment of double-wall pipes at the six o'clock position. Low voltage is applied between the cable's two sensor wires. Contact with a leak bridges the gap between the sensors, completing an electrical circuit that activates the alarm.

- Sensing cables are available to detect fuels, solvents, and aqueous fluids.
- Sensing circuits can be branched using connectors to accommodate complex piping arrangements.

### Jumper Cable

Jumper cable is the system's interconnect cable.

- The maximum length of standard jumper cable is 10,000 feet. Longer lengths may require factory assistance

### System Map

The TraceTek system is designed to be used in conjunction with a graphic system map prepared from "as built" drawings. The system map should be mounted near the alarm module, should show the pipe layout and the location of all pipe access points, and should indicate actual cable distance readings at each access point.

### Approvals

The system has been approved by:

- Underwriters' Laboratories, Inc., (UL)
- Factory Mutual (FM)
- Canadian Standards Association (CSA)  
For approval details, see Table 3 on page 27.

### Certifications

The system meets the requirements for Carnegie Mellon Research Institute Certification ("Test Procedures for Third Party Evaluation of Leak Detection Methods: Cable Sensor Liquid Contact Leak Detection System").

# 3. General Project Considerations

Leaks are likely to occur even in the best engineered systems. The following are some considerations to address when selecting the leak detection approach.

## **Environmental Hazards**

- What are the characteristics of the fluids handled?
- Are they flammable, toxic, or corrosive?
- Is the installation in an ecologically sensitive area, as near an aquifer?
- What is needed to comply with local regulations?

## **Probability of a Leak**

- What are the conditions and complexity at the specific facility?
- What are the routine practices at the facility?

## **Impact on Operations**

- What is the potential for property damage or injury?
- What is the cost of down time or disruption?

## **Accessibility of Pipe**

- Is the pipe above or below grade?
- Is the pipe located beneath buildings or other concrete emplacements?

## **Coverage**

- What are the length and accessibility of branch sections?

## 4. Overview of Key Design Parameters

The following points outline the mechanical design and installation requirements for a cable-ready double containment pipe system.

### Clearance

- Ensure minimum 0.75-inch clearance throughout the piping system.
- Place sensing cable at the bottom of the pipe.
- Specify appropriate pipe sizing (such as 1x4, 2x6) on drawing.

### Pull rope

- Use 0.25-inch- or 0.75-inch diameter, hollow-braid, polypropylene rope; no substitutions.
- Ensure that the pull rope is continuous, not tangled, knotted, pinched, or glued.

### Installation

- Install connectors in access points.
- Align and fix centralizers to primary pipe.
- Avoid sharp angles and edges throughout the pipe system.
- Pull sensing cable before burying pipe.
- Ensure the pipe system is clean and dry.

### Sealed Containment

- Ensure leak does not enter environment.
- Exclude liquids other than leaks.

### Access points

- Incorporate 4-inch nominal fittings.
- Extend to within 8 to 10 inches of grade.
- Protect with manhole covers.

Needed for:

- Installation/service of sensing cable.
- Investigation of leaks
- Pipe drying.
- Mapping of reference points.

Needed in piping at:

- Beginning and end of each run.
- Beginning and end of sensed branches.
- At the following intervals:  
  - < 1-inch annular clearance: After 180° of pipe bend or every 250 feet of straight pipe.
  - > 1-inch annular clearance: After 360° of pipe bend or every 400 feet of straight pipe.

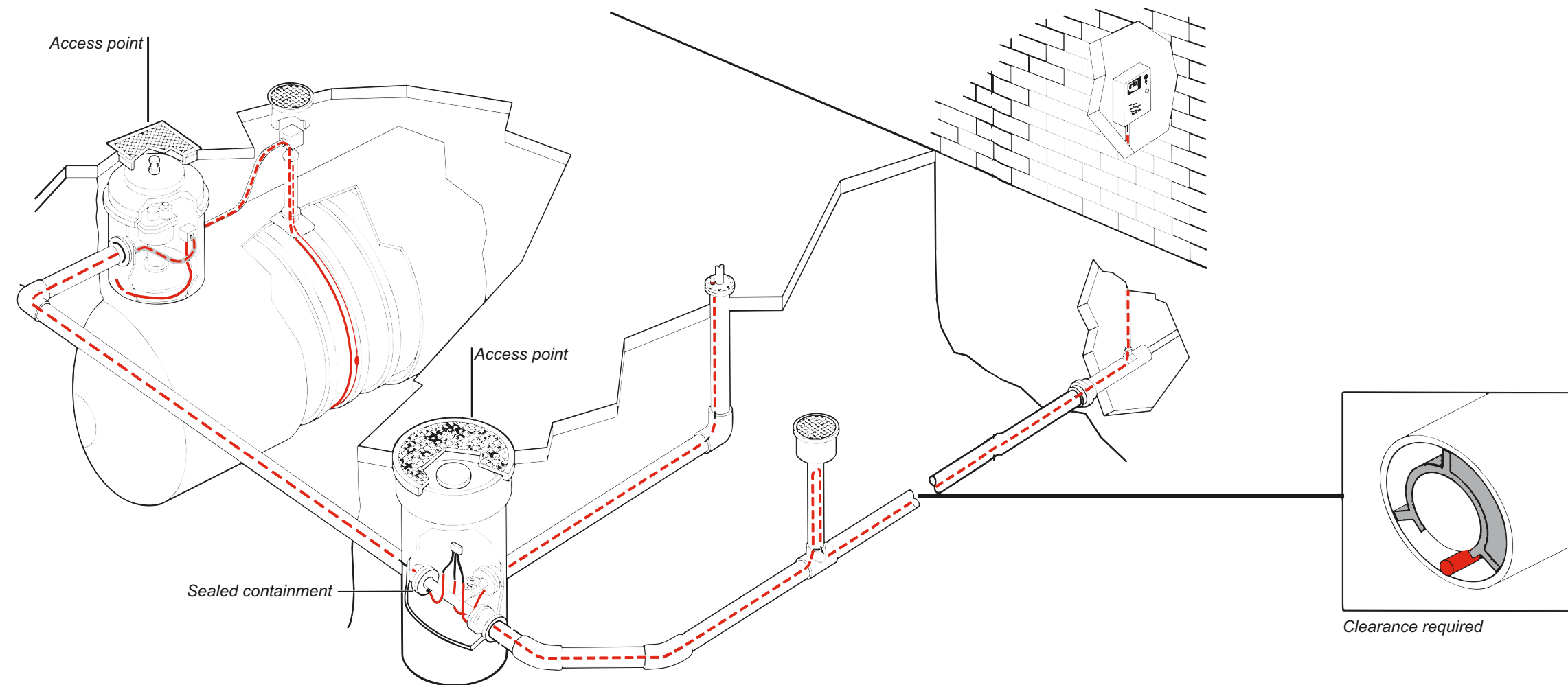



## 5. Mechanical Design/Installation Requirements

This section describes mechanical design and installation requirements for double containment piping that will be monitored by a cable-type leak detection system. Included in this section is a piping specification supplement (beginning on page 17) that must be incorporated into the "Division 15: Mechanical" portion of the piping system specification.

The following sections amplify what is contained in the specification supplement by:

- Providing guidance for the design of a cable-ready pipe system.
- Outlining the mechanical engineers or mechanical contractor's responsibilities.

It is the mechanical engineers responsibility to:

- Verify that the mechanical design guidelines are met.
- Determine whether the pipe to be used meets the requirements for clearance, pipe size, centralizers, containment access, pull rope, drains, and sealing.
- Specify the leak detection system as part of the electrical or instrumentation portion of the specification or, alternatively, provide a separate section for leak detection in the specification.

### Clearance

A minimum clearance is required at the 6 o'clock position in the piping system in both straight sections and fittings to ensure that the sensing cable can be properly installed.

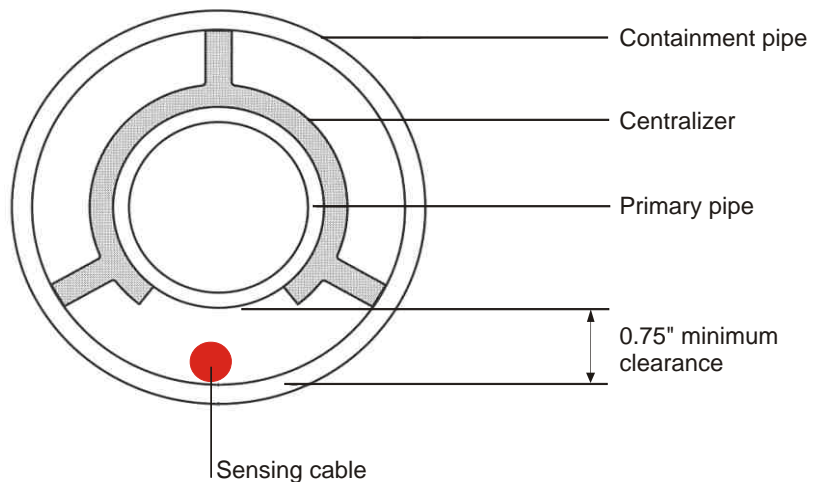

Even when the piping system is designed for this 0.75-inch containment space, special care must be taken to ensure that the minimum clearance is maintained during installation. Interference to pulling may occur due to weld beads (as in the case of the butt fused pipe shown below) or glue beads (as in the case of the bell and spigot pipe shown below) at the pipe coupling.

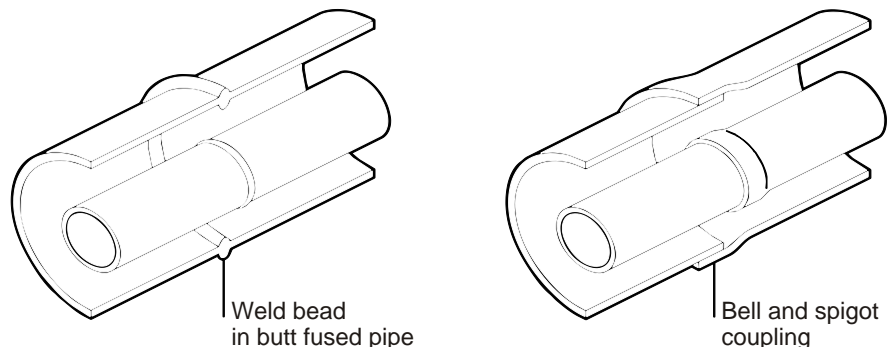

## Pipe Sizing

Use Table 1 as a guideline to specify the diameter of the primary pipe and the containment pipe to provide the 0.75-inch containment space.

**Table 1. Suggested Pipe Sizing** (dimensions in inches)

Primary Pipe	Containment Pipe	Primary Pipe	Containment Pipe
1	4	8	12
2	6	10	14
3	6	12	16
4	8	14	18
6	10	16	20

## Multiple Pipes

For multiple pipes installed in a single containment pipe, contact the factory for engineering guidance.

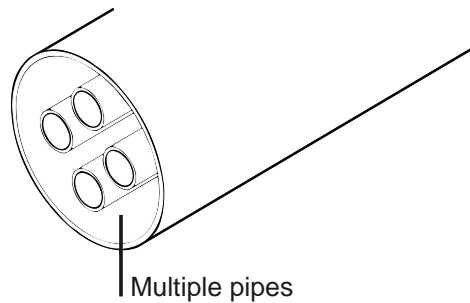

## Centralizers

Centralizers are required for structural support. They must be designed to:

- Position the primary pipe within the containment pipe.
- Withstand loads of filled pipe to prevent the primary pipe from sagging.
- Withstand lateral loads due to thermal expansion.
- Allow liquid to pass through the containment space so it can be drained.
- Allow air to pass through the containment space so it can be dried.

The centralizers themselves must be:

- Free of sharp edges and pinch points.
- Aligned within  $\pm 5^\circ$  during installation (to ensure a straight pull path).
- Fixed to the primary pipe.

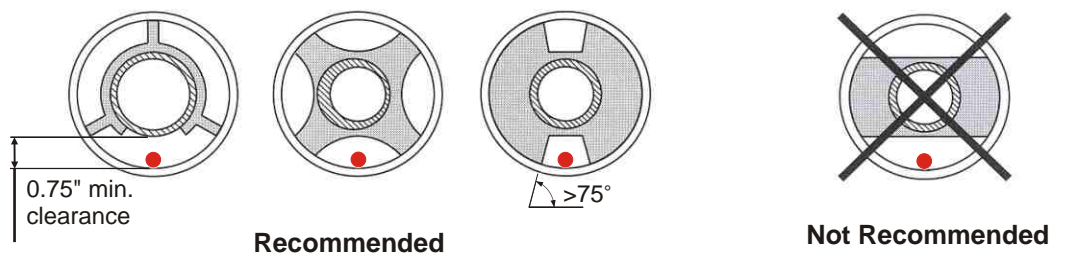

---

## Fittings

Sweep 90°s are recommended to facilitate the installation of the sensing cable. Conduit should be fastened into fittings that have mitered joints or into pipes with radius differences that create pinch points. A 0.75-inch conduit with a minimum 4.5-inch bend radius is recommended when installing preconnectorized sensing cable. The conduit must have flared ends without rough edges to reduce resistance to pulling.

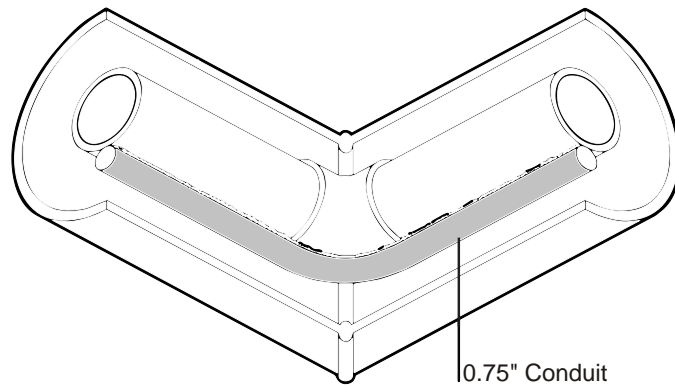

## Containment Access

Access to containment pipe is necessary for:

- Installation of sensing cable
- Investigation of secondary containment; cleanup; and drying.
- Maintenance/service of sensing cable.

Different kinds of access to the containment pipe are possible, depending on the piping design. The following three design scenarios are covered in this section:

- Below ground pipe.
- Segmented pipe.
- Exposed containment pipe.

In General, access to the containment should be positioned as described in Table 2.

**Table 2. Containment Access Requirements**

---

At the beginning and end of each pipe run.

---

At each branch or lateral that is sensed.

---

At intervals specified below.

---

<b>Annular clearance</b>	<b>Required location of access points</b>
< 1-inch	After 180° of pipe bend or every 250 feet of straight pipe
> 1-inch	After every 360° of pipe bend or every 400 feet of straight pipe

---

### Below Ground Pipe

To provide access into a buried double containment pipe, 4-inch-minimum-diameter tees that rise up to grade must be incorporated into the pipe containment. Each access riser should extend from the pipe to within eight to ten inches of grade and be protected by a manhole cover that is set in concrete of appropriate thickness to prevent damage to the pipe.

Manhole covers: Each manhole cover must:

- Be an appropriate size (at least 6" greater than the riser diameter; for example, a 4" riser requires a 10" cover).
- Have a surface that is one inch higher than the grade.
- Have a surface that is gradually sloped to the grade to resist drainage into the access area.

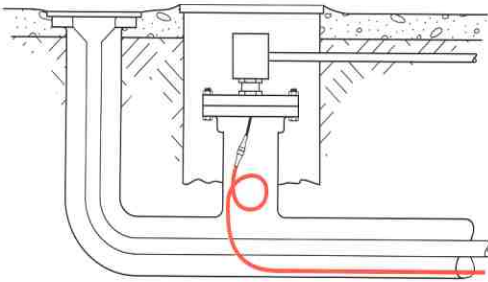

*Cable entry access*

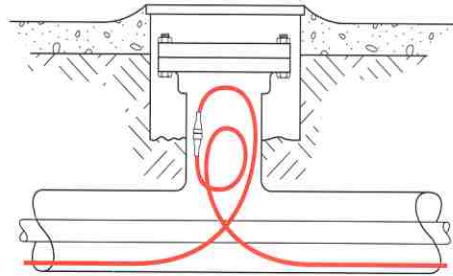

*Intermediate access*

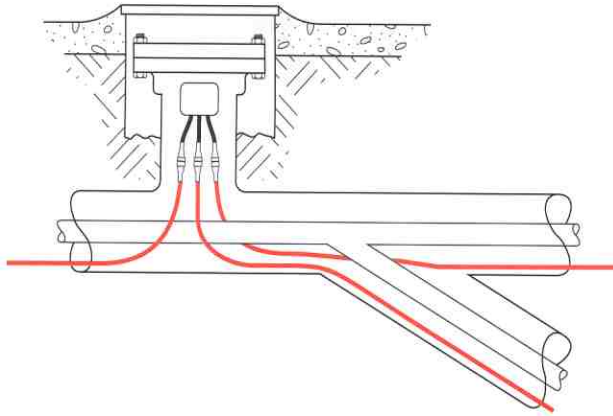

*Lateral with access riser*

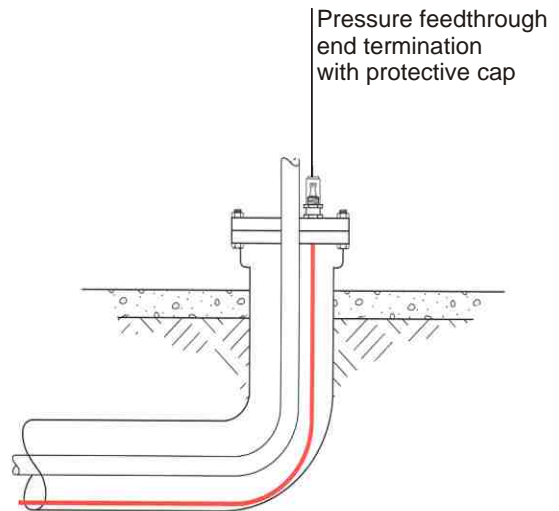

*Containment terminator*

---

### Segmented Pipe

If the pipe is segmented at manholes or vaults, use saddles or end-plate penetrations instead of access tees and risers for cable entry and exit points.

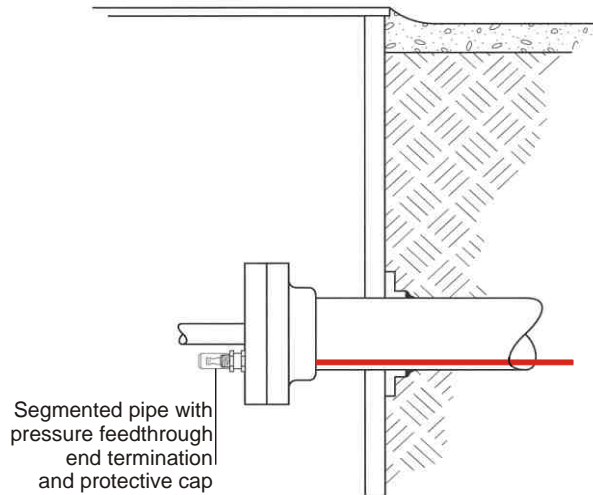

### Exposed Containment Pipe

Under some conditions, portions of the containment pipe may be above ground or accessible within buildings, tunnels, vaults, and manholes, in which case the cable entry and exit techniques just described for segmented pipe may be appropriate. Access points must be located at the intervals shown in Table 2 (page 12).

### *Pull Rope*

A pull rope is used to pull the sensing cable through the containment pipe. It must be:

- A 0.25-inch or 0.375-inch hollow-braid polypropylene rope (no substitutes are acceptable).
- Continuous and free of tangles or knots.
- Loose in the pipe, not pinched or glued in.

The rope is installed as the pipe is being assembled in the field. Factory assembled sections of pipe may include preinstalled lengths of pull wire, which may be used to draw the continuous hollow-braid pull rope into place.

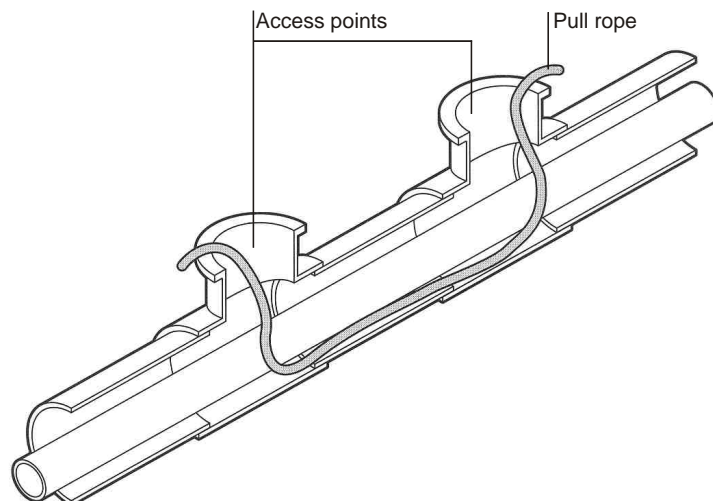

---

### Pull rope for Simultaneously Fused, Mirror-welded Pipe

Some pipe systems are simultaneously welded with mirror-welding techniques. These installations may require special attention in order to install the pull rope.

Two types of mirror-welding tools are used for these installations:

- Solid-mirror welders: These tool preclude installation of the pullrope while pipe sections are being joined. Typically, a fish tape is used to install the pull rope after a short series of welds are completed. Distance between the pull points is limited to the practical working length of the fish tape.
- Split-mirror welders: These tools provide a hole in the hinged welding mirror that allows a metal lead wire to pass through. Hollow-braid polyethylene pull rope is pulled into place using the metal lead wire.

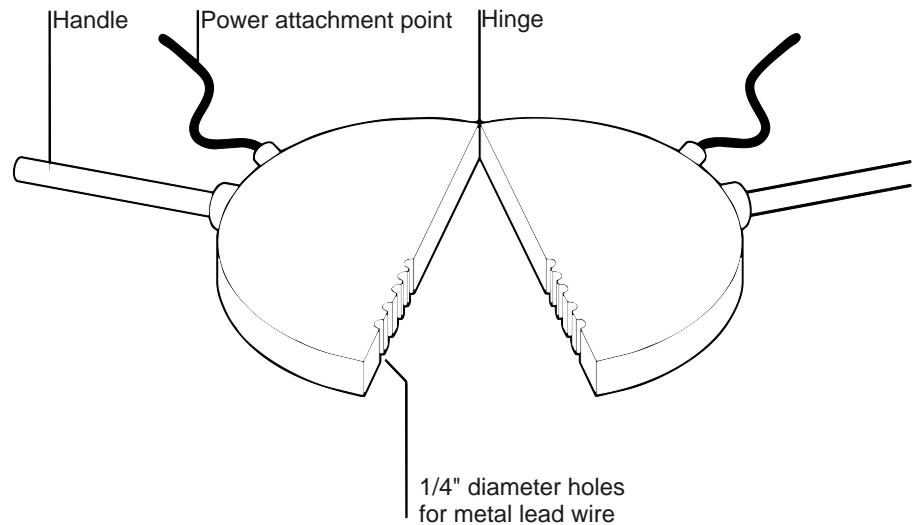

### *Low-Point Drains*

To remove liquid from the containment pipe, drains are recommended at periodic intervals of the pipe.

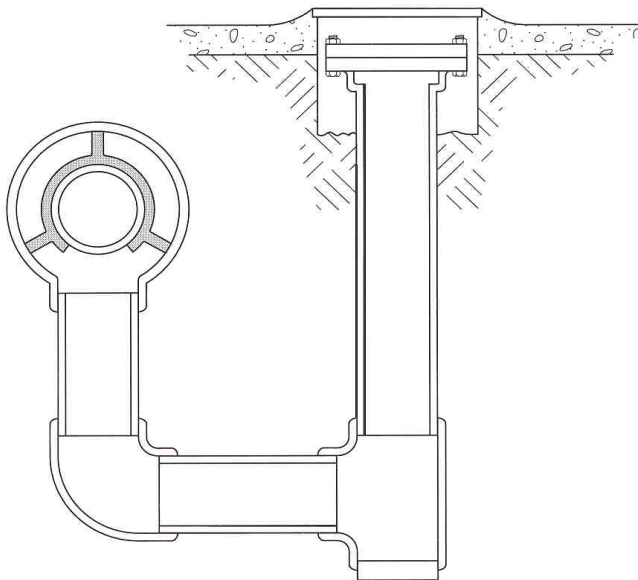

---

## ***Sealing of the Containment Pipe***

Secondary containment pipes must be sealed from the environment in order to:

- Contain leaks.
- Avoid ingress of ground water and rain.
- Minimize the potential for condensation.

Special care should be taken at manholes, sumps, valve pits, and vaults to ensure a sealed containment.

## ***Mechanical Contractor's Handoff Requirements***

The mechanical contractor is responsible for keeping the containment piping clean and dry. Before handoff to the leak detection installer the mechanical contractor must demonstrate that the containment piping is ready for installation of the sensing cable. To accomplish this the contractor must:

- Pressure test the pipe.
- Inspect the pull rope.
- Do a demonstration pull.
- Dry the pipe.
- Hand over "as built" drawings to the sensing cable installer.

### **Piping Pressure Tests**

Two types of pressure test may be performed on the piping:

- Hydrostatic test
- Pneumatic test

The pneumatic test is preferred when testing the containment piping since it reduces the amount of liquid that must be removed from the containment space.

### **Pull rope inspection**

The mechanical contractor must verify that the pull rope is:

- A 0.25-inch- or 0.375-inch-diameter hollow-braid polypropylene rope.
- Installed from access to access.
- Knot-free in the pipe.
- Loose in the containment

### **Annular Clearance Inspection/Pull Rope Demonstration**

A satisfactory annular clearance is demonstrated by a successful back-to-back pull. This is done by first attaching a cable pulling tool to the installed (initial) pull rope, which in turn is attached to a second pull rope. The contractor then pulls the initial pull rope through the containment pipe. As the initial pull rope is removed, it should be visually inspected for mud, dirt, other contaminant's, and wetness. If any of these elements are present, reasonable cleanup methods must be employed.

### **Drying the Pipe**

Before the sensing cable is installed, the containment piping should be dried with forced air moving down the gradient of the pipe. (Should there be any water in the containment, forcing air up the pipe would blow the water throughout the pipe, making it much more difficult to dry).

### **Handoff**

Handoff takes place when the above steps have been satisfactorily completed and the piping contractor or mechanical contractor has supplied "as built" drawings to the sensing cable installer.

---

## *Mechanical Specification Supplement*

### **Division 15: Mechanical Design Requirements for Double Containment Piping used with Cable-Type Leak Detection Systems**

#### **Purpose**

The information outlined in this supplement describes the requirements for the mechanical design and fabrication of piping system that will use cable-type leak detection systems.

#### **Part 1. General**

**1.1** Installation of cable-type leak detection systems requires the coordination of multiple trades. The general contractor shall ensure that the mechanical and electrical contractors understand their responsibilities and that schedules are coordinated. In the absence of a primary electrical contractor, the mechanical contractor shall utilize the services of a qualified electrician to install and commission the leak detection system.

**1.2** The mechanical contractor shall be responsible for fabricating the double containment piping system in such a manner that leak detection sensing cable may be installed. During assembly the mechanical contractor shall install a 0.25-inch- or 0.375-inch-diameter knot-free, hollow-braid polypropylene pull rope in the bottom of the containment pipe. Upon completion of the installation, the pull rope shall be continuous from access point to access point and shall be capable of free movement without obstruction.

**1.3** During construction, care shall be taken to assure that the containment space is kept clean and dry. The mechanical contractor is responsible for removing any water, moisture, mud or other debris from the containment space prior to releasing the piping system for sensing cable installation. The containment pipe shall be fabricated such that it is liquid tight and sealed from the environment

#### **Part 2. Products**

**2.1** Pipe system materials shall be specified by the engineer.

**2.2** Centralizers shall be used to provide structural support and to position the primary pipe in the containment. Centralizers shall be spaced as specified in order to assure that the primary pipe is completely supported during operating conditions (that is, with full weight of the fluid load, under thermal expansion stress, etc.).

**2.3** Openings at the bottom of the centralizer shall ensure a minimum of 0.75-inch clearance for the installation of the pull rope and sensing cable. Centralizer design shall preclude any narrow angles, sharp edges, or other pinch points that could cause the pull rope or sensing cable to become wedged, pinched, or otherwise damaged during installation.

**2.4** Access points shall be used to facilitate the installation of the sensing cable in the containment space. These access points shall be located at the beginning and end of the main pipe run, at the beginning and end of all sensed branches, and at periodic intervals as follows:

<1-inch annular clearance: After 180° of pipe bend or every 250 feet of straight pipe.

>1-inch annular clearance: After 360° of pipe bend or every 400 feet of straight pipe.

**2.5** Access risers (tees in the containment pipe that rise to within 8 to 10 inches below grade) shall be a minimum of 4 inches in diameter and shall be accessible from the finished grade without excavation.

**2.6** Each prefabricated or field-fabricated piping section may include a pull wire. The pull wire shall be used as an aid to install a continuous 0.25-inch-or 0.375-inch-diameter hollow-braid polypropylene pull rope; no substitutions for the rope shall be acceptable. The pull rope will be used for sensing cable installation. The pull wire shall be disposed of when it is no longer needed to pull in the continuous rope. Spliced or knotted sections of pull wire are not acceptable as the final pull rope.



---

**2.7** Recommended: Low-point drains shall be installed at periodic intervals along the pipe for removing liquid from the containment space.

**Part 3. Execution**

**3.1** The contractor shall ensure that the centralizers are bonded to the primary pipe during installation, to prevent movement of the centralizer when the primary pipe is inserted into the containment.

**3.2** Centralizers shall be aligned to within +/- 5° to ensure an obstructed path for the pull rope and sensing cable at the 6 o'clock position of the annular space.

**3.3** Access risers shall be capped with a re-enterable, sealed fitting and be protected from surface traffic with a minimum 10-inch-diameter or appropriately sized manhole cover (6 inches larger than the riser diameter). The manhole cover's finished level shall be at least 1 inch above the finished grade. A beveled concrete apron shall be installed around the manhole cover assembly to prevent water from draining into the valve pit.

**3.4** A hollow-braid polypropylene pull rope (0.25 inch or 0.375 inch in diameter) shall be installed throughout the piping system during fabrication. The pull rope shall be continuous and knot-free between access points and be unobstructed and loose in the pipe.

**3.5** The contractor shall take special care with glued couplings or butt-fused pipe to ensure that the weld bead or glue bead does not obstruct the 0.75-inch clearance required for the pull rope and sensing cable at the 6 o'clock position in the containment space. Short sections of aircraft cable maybe used as a leader during pipe joint assembly to prevent the continuous pull rope from becoming glued, welded, melted, dissolved, or otherwise damaged during fabrication.

**3.6** The mechanical contractor shall take all necessary precautions to prevent water, snow, ice, mud, dirt, or any other debris from entering the containment space during pipe installation. Any standing liquid, moisture, or debris that does accumulate in the containment during installation or hydrostatic testing shall be removed by the mechanical contractor. If water or other contaminant's are discovered during sensing cable installation, they too shall be removed by the mechanical contractor.

**3.7** The piping system shall be handed off for sensing cable installation after all hydrostatic and pneumatic testing is complete. The mechanical contractor must demonstrate that the minimum 0.75-inch clearance has been met, that the pull ropes have been installed from access to access, and that they are loose and free in the pipe. This shall be accomplished by a cable pull test in which the cable pulling tool is used to pull an additional pull rope through the pipe. The initial pull rope shall be visually inspected for mud, dirt, or wetness. The piping system shall be clean and dry for the handoff to be complete.

**3.8** The mechanical contractor shall provide the sensing cable installer with a set of "as built" pipe drawings. These drawing shall be used by the installer to prepare the lead detection system map.

## 5. Mechanical Design/Installation Requirements

This section describes the electrical requirements for a cable-type leak detection system for double containment pipe. Included in this section is an electrical specification supplement beginning on page 24 that must be incorporated into the "Division 16: Electrical" portion of the piping system specification. To facilitate proper installation and improve reliability, the leak detection system should be specified as part of the electrical or instrumentation portion of the specification, or alternatively, be provided in a separate section for leak detection.

Most of this section amplifies what is contained in the specification supplement, providing guidance for the electrical design and installation of the system.

### *Power Requirements*

Each alarm module requires

- A dedicated 15-amp, 115/230-volt ac circuit

### *Hookup Requirements*

The leak detection supplier should provide:

- Alarm module(s)
- Jumper cables
- Sensing cables
- Feedthrough fittings
- All connection components

The leak detection installer should provide:

- Conduit
- Safety barrier enclosure (required for CID1 locations)
- Sealtite™ fittings (optional)
- Flexible conduit
- Junction boxes

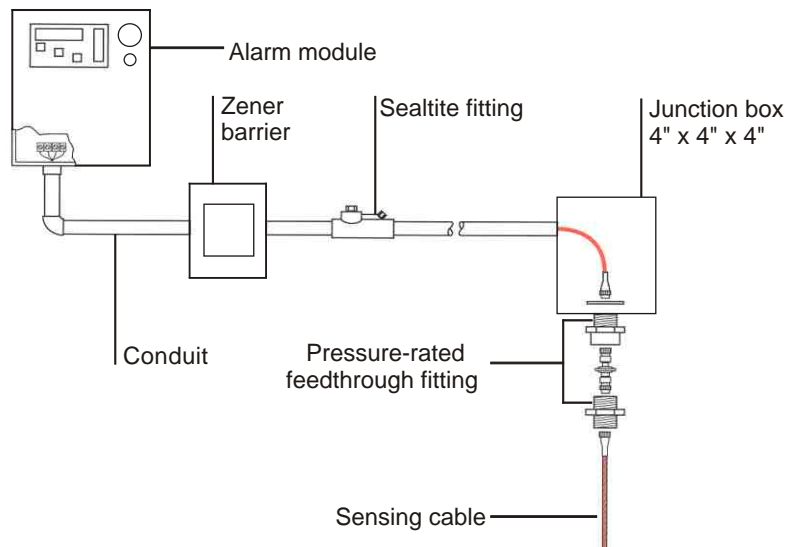

---

### Safety Barriers and Enclosures (required for CID1 locations)

When the sensing cable is to be operated in a Class I, Division 1 hazardous location, a zener safety barrier must be installed between the alarm module and the containment-pipe entry point. The zener barrier assures that energy transferred to the sensing cables will remain below intrinsic safety limits and will reduce the risk National Electrical Code.

An appropriate device that meets these requirements can be purchased from MTL Incorporated, 8657 Wellington Road, Manassas, Virginia, 22110-1690; phone (703) 361-0111; fax (703) 368-1029. Catalog description: MTL-765 zener barrier MT-Z enclosure. Note: Safety barrier must be installed in accordance with manufacturer's instructions.

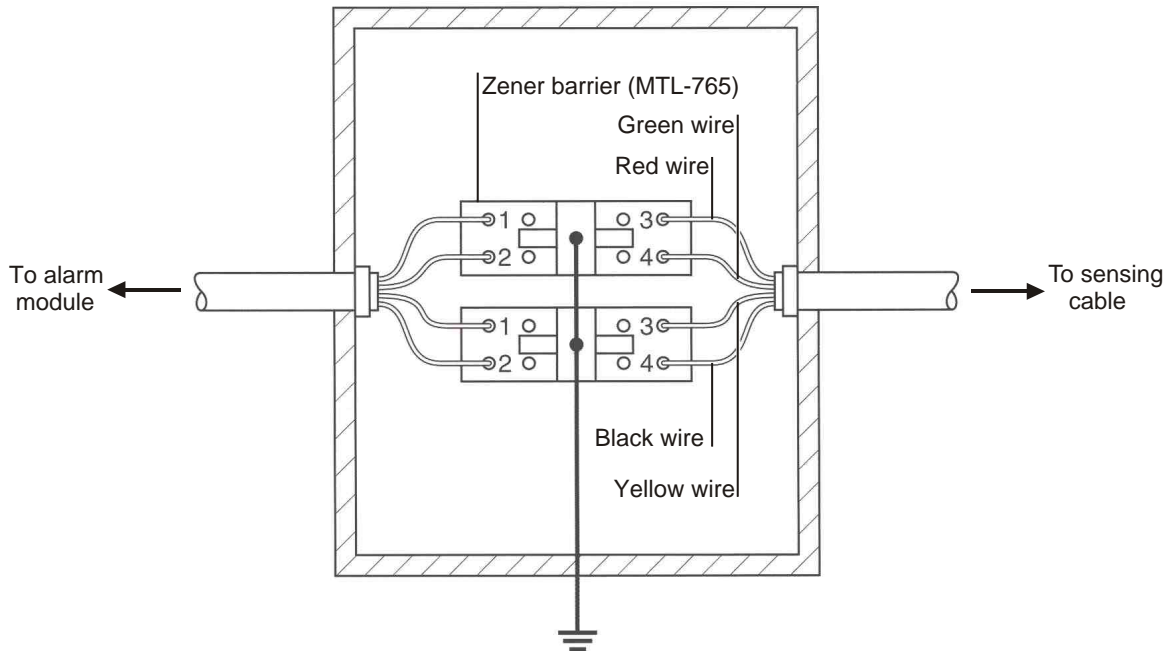

### Junction Boxes

Junction boxes should be installed at the location of each sensing cable penetration. They should be type NEMA 4X (above grade) and/or NEMA 6 (below grade).

Junction boxes used at the point of entry require a minimum box size of 4 x 4 x 4 inches. Junction boxes used for branch connectors require a minimum box size of 6 x 6 x 4 inches.

### *TraceTek Leak Detection Installation*

When the mechanical contractor has completed the handoff requirements per section 3.7 of the Mechanical Specification Supplement (see page 18), the TraceTek Installation begins. The electrical contractor's responsibilities include:

- Mounting the alarm module.
- Installing the conduit, junction boxes, fittings, jumper cable, optional zener barrier, and sensing cable.
- Performing the acceptable testing.
- Purging the containment.
- Preparing a system map.

### Mounting the alarm module

The alarm module must be installed according to the manufacturer's directions.

---

### Installing the Sensing Cable

The first sensing cable is installed from the cable entry point to the first access point. Subsequent lengths of sensing cable are installed from access point to access point. The pull rope installed by the mechanical contractor is used to pull the sensing cables through the containment piping.

No lubricants should be used when installing the pull rope or sensing cables.

Installed sections of sensing cable and field-installed connectors should be tested as they are attached. To do this, a portable test instrument or ohm meter should be used, according to the sensing cable installation instructions.

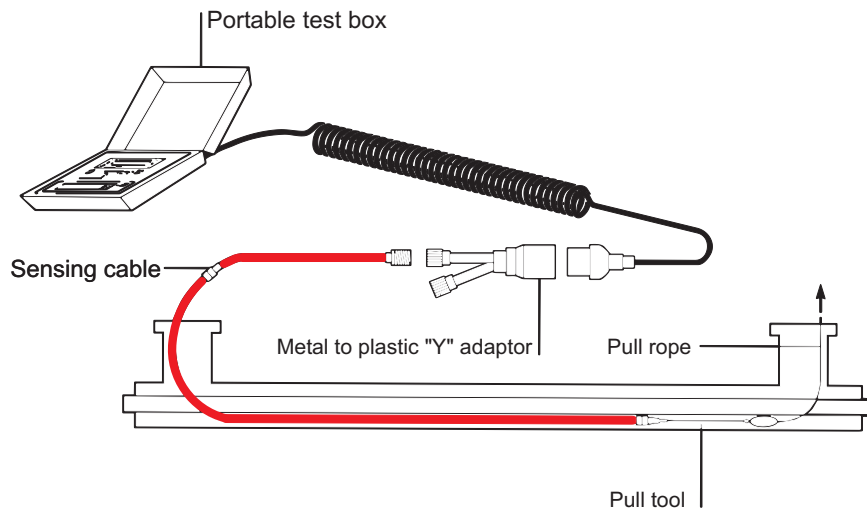

Optional: The modular branching connector should be installed in the access riser so that the sensing cables are not pulled around angles greater than 90°.

### Service Loop

A connector with a service loop should be accessible at each access point. Sufficient sensing cable is required at the access point to allow for maintenance at grade level.

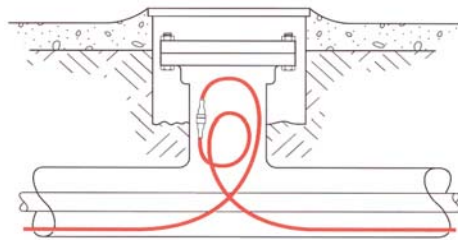

*Service loop*

---

### Terminating the Sensing Cable

The modular end termination can be handled in two ways: it can be placed inside the access point at the end of the service loop or be brought through the pipe wall using a pressure feedthrough fitting as shown below.

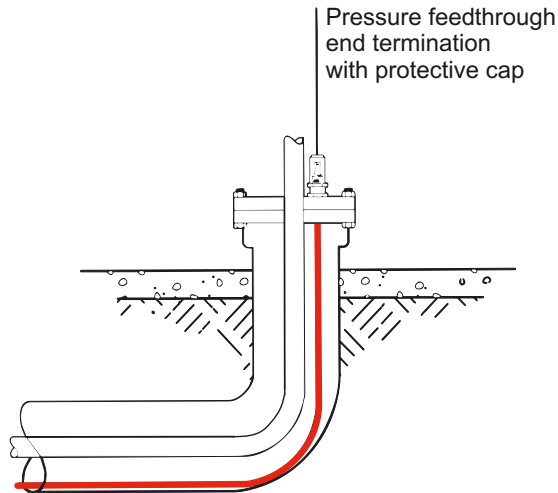

### Performing the Acceptance Testing

In order to simulate possible leak conditions in the pipe and to verify system performance, the following acceptance testing is required upon completion of the system installation:

- A five-foot length of factory preconnectorized sensing cable must be temporarily installed at the far end of each leak detection circuit.
- The water (or aqueous chemical) sensing cable, if installed, must be immersed in a one-foot-diameter puddle of water at a depth of 0.125 inch to confirm that an alarm will be generated and the appropriate distance is indicated on the alarm module.
- The five-foot hydrocarbon sensing cable, if installed, must be tested in the same manner as the water sensor but with the appropriate hydrocarbon. (The hydrocarbon sensing cable used in this test is discarded after the testing is completed).



**WARNING!** When performing this test use appropriate safety procedures for handling flammable fluids.

The installer must perform and certify the tests in the presence of the owner's representative.

---

### *Purging the Containment Pipe (aqueous systems only)*

Upon completion of the acceptance testing and removal of the temporary test section, the piping containment must be purged with -20°F dew-point air or dry nitrogen. After the purging the containment must be sealed.

### *Preparing a System Map*

Upon completion of the installation, the leak detection installer must prepare a graphic display map from the “as built” drawings received from the mechanical contractor. The map must indicate, per manufacturer’s instructions, the location of:

- The sensing cable and connectors
- Distance readouts along the sensing cable to landmarks, such as:
  - Equipment
  - Piping access points (manholes and vaults)
  - Tanks
  - Changes of cable direction

The map must then be mounted next to the alarm module.

### *Commissioning the System*

The commissioning procedure includes system measurements taken with a portable test instrument and an ohm meter. This procedure is intended to ensure a functional system.

The Commissioning/Service Record form must be completed by the installer or leak detection supplier and signed off by the system owner.

When the commissioning has been completed, the supplier of the leak detection system should provide the following to appropriate operators and personnel:

- Operator training
- Operations and maintenance manuals

---

## *Purging the Containment Pipe (aqueous systems only)*

### **Division 16: Electrical Design Requirements for Cable-Type Leak Detection in Double Containment Piping**

#### **Purpose**

The information outlined in this supplement describes the requirements for a successful installation of cable-type leak detection in double containment piping systems.

#### **Part 1. General**

**1.1** Installation of cable-type leak detection systems requires the coordination of multiple trades. The general contractor shall ensure that the mechanical and electrical contractors understand their responsibilities and that schedules are coordinated. In the absence of a primary electrical contractor, the mechanical contractor shall use the services of a qualified electrician to install and commission the leak detection system.

The electrical contractor shall be responsible for installing the alarm module, sensing cable, and components according to the manufacturer's instructions.

#### **Part 2. Products**

Cable-type leak detection materials shall be specified according to the product specification guidelines for Aqueous Chemical, Fuel, or Fuel and Water Leak Detection for Containment Piping.

#### **Part 3. Execution**

**3.1** The alarm module shall be installed in an ordinary area at the location designated on the project plans. The installer shall provide the necessary hardware to securely attach the module to the wall surface at the mounting location. A dedicated (115 Vac/230 Vac) 15-amp circuit shall be provided for each alarm module. The power circuit shall include a circuit breaker suitable for de-energizing the alarm module during wiring and maintenance.

**3.2** Conduit, flex conduit, and watertight junction boxes shall be installed as necessary to connect the alarm module to the nearest pipe-entry access, in manholes or vaults, and at the location of each sensing cable end termination. Optional: If intrinsically safe output circuits are required, an enclosure for the zener barrier shall be installed between the alarm module and entry to the hazardous area. Sealtite™ fittings shall also be installed in the conduit run to prevent the migration of explosive vapors.

**3.3** All jumper cable shall be supplied by sensing cable manufacturer. Transition from the conduit and junction boxes to the annular space of the containment system shall be made with a pressure-rated feedthrough fitting.

**3.4** The 4-inch x 4-inch x 4-inch junction boxes shall be installed at the location of each pressure-rated feedthrough fitting, 6-inch x 6-inch x 4-inch junction boxes shall be at the location of each branching connector installed outside of the annular space of the containment system. All junction boxes shall be type Nema 4X if installed above grade and type Nema 6in if installed below grade.

**3.5** Upon completion of the handoff requirements per section 3.7 of the Mechanical Specification Supplement, sensing cable shall be installed in the annular space of the containment system. The sensing cable shall be installed in accordance with the manufacturer's instructions. No lubricant shall be used to assist in sensing cable installation.

**3.6** As it is being installed, each section of the sensing cable shall be monitored with a portable test instrument to detect possible sensing cable damage and the presence of liquid(s) of the type to be detected (aqueous or hydrocarbon) in the annular space. During installation, sections of cable that indicate liquids(s) have been detected shall be removed and the condition reported to the mechanical contractor for correction. The sensing cable shall be installed from access to access. The installer shall ensure that there is a sensing cable connector at each access point and that there is sufficient service loop in the sensing cable to allow for its grade-level testing and maintenance.



**WARNING! When performing this test use appropriate safety procedures for handling flammable fluids.**

---

**3.7** All accessories (including branching connectors, weighted lengths, and end terminations) necessary to complete the sensing cable system shall be installed in accordance with the project plans and the manufacturer's instructions.

**3.8** Mapping the System. Upon completion of the system installation, the installer shall generate alarm readings at all access points, valve pits, sumps, or other accessible locations in accordance with the manufacturer's mapping procedure. Records of the sensing cable layout and mapping readouts shall be recorded on "as built" drawings as supplies by the mechanical contractor.

**3.9** Acceptance Testing. Upon completion of the system installation, a factory preconnectorized five-foot length of sensing cable of each type installed shall be temporarily installed at the far end of each leak detection circuit. The aqueous chemical (or water) sensor shall be immersed in approximately one foot of water at a depth of 0.125-inch to confirm that an alarm is generated and the appropriate distance is indicated on the alarm module. The five-foot hydrocarbon sensor shall be tested in the same manner using the appropriate hydrocarbon and shall be discarded upon completion of the test. The installer shall perform and certify the tests in the presence of the owner's representative.

**3.10** Containment Purging (aqueous systems only). Upon completion of all testing, removal of temporary sensing cable test sections, and systems mapping, the annular space of the containment system shall be purged with -20°F dew-point air or dry nitrogen. The containment space shall be sealed after purging.

**3.11** System Map. A graphic display map prepared from "as built" drawings shall be furnished upon completion. The map shall indicate the location of the sensing cable and landmarks such as equipment, piping access points, change of cable direction, and cable distance readings per the manufacturer's instructions. The map shall be mounted near the alarm module.

**3.12** Commissioning. A commissioning/service form shall be completed by the installer or the leak detection supplier and signed off by the system owner. The commissioning procedure includes system measurements using a portable test instrument and an ohm meter to ensure a functional system.



# 7. Summary of Contractor

---

Installation of leak detection in double-contained pipe requires coordination of multiple trades. The general contractor shall ensure that mechanical and electrical contractors understand their responsibilities and that schedules are coordinated.

In the absence of a primary electrical contractor, the mechanical contractor shall utilize the services of a qualified electrician or subcontractor to install and commission the sensing cable and alarm module.

The responsibilities of the mechanical and electrical contractors are outlined in the sections that follow.

## *Mechanical Contractor's Responsibilities*

The mechanical or piping contractor is responsible for the proper assembly and installation of the double-wall pipe system that will receive the cable-type leak detection system. These responsibilities are spelled out in detail in Section 5. They include the following procedures:

- Ensuring correct pipe sizing
- Selecting and installing centralizers
- Cleaning and drying the containment space
- Installing pull ropes
- Meeting all mechanical handoff requirements
- Providing "as built" drawings to the electrical contractor

## *Electrical Contractor's Responsibilities*

The electrical contractor is responsible for installing the alarm module, sensing cable, and components according to the manufacturer's instructions. These responsibilities, detailed in Section 6, include the following procedures:

- Mounting the alarm module
- Providing electrical hookups
- Monitoring for moisture
- Providing for service loops
- Installing accessories
- Testing cable sections
- Mapping the system
- Conducting acceptance testing
- Purging the containment after final testing
- Sealing the containment
- Preparing a system map
- Commissioning the system

# 8. System Descriptions for Other Applications

Cable-type leak detection systems are also available for other applications. This section presents three of these applications:

- Double-contained tanks
- Pipe and tank combinations
- Trenches and sumps

Table 3 provides a matrix of system capabilities and applications that will help in the selection of products for various double-wall applications.

**Table 3. Product Selection Matrix**

	<b>System Type</b>			
	<b>Long Line</b>	<b>Zone</b>	<b>Multichannel</b>	<b>Single Channel</b>
Module type*	TTB	TTB	TTG	TTA-I-UL
General use	Large or long distance	Many discrete areas	Several discrete areas	Single area
Applications	D/C pipe/tanks trenches, subfloors	Multiple sumps, wet benches, valve boxes	D/C tanks, sumps	Equipment, sumps
Max. number of sensing cables	2000-ft or 1000 m	50 points	12 points	1 point
Alarms on cable break	Yes	Yes	Yes	Yes
Single run of	Yes	Yes	No	Yes
Max. length of standard jumper cable	10,000 ft	10,000 ft	10,000 ft	10,000 ft
Relay contacts	SPDT	SPDT	SPDT	SPDT
Display	Feet/meters	Zone number	Channel lights	Light
Audible alarm	Yes	Yes	Yes	Yes
Approvals	UL, CSA- Ordinary Areas FM-Hazardous Location Class I, Div. 2, Gr. A, B, C, D	UL, CSA- Ordinary areas FM-Hazardous Location Class I, Div. 2, Gr. A, B, C, & D	UL-Hazardous Location Class I, Div. 1 & 2, Gr. A, B, C, & D	UL-Hazard Location Class I, Div. 1 & 2, Gr. A, B, C, & D CSA- Ordinary Areas
Analog interface	Yes	Yes	No	No
Independent channels	No	No	Yes	Yes
Locates along sensor path	Yes	No	No	No
Branching capability	Yes	Yes	Yes	Yes

	<b>Sensing Cable</b>		
	<b>TT3000</b>	<b>TT501</b>	<b>TT502</b>
Fluid to detect	Any conductive fluid: acids, bases, industrial waste, leachate, water	Solvents: TCE, trichloroethane, toluene, and others.	Hydrocarbons and oils,: gasoline diesel, hydrocarbon, JP-4, heating oil, motor oil, hydraulic fluid
Undetected fluids	Hydrocarbons or solvents	Water, acids, bases	Water, acids, bases

\* For information on other TraceTek modules, consult factory.

---

## Double-Contained Tanks

Two sensing cables may be installed in the annulus between the primary tank and secondary containment:

- The hydrocarbon sensing cable will detect fuels or solvents entering from a break in the primary tank, yet will ignore the presence of water. The hydrocarbon sensing cable must extend the full height of the tank annulus to provide distributed coverage from the top to the bottom of the tank.
- The water (or aqueous chemicals) sensing cable will detect water entering from a breach in the secondary containment, yet will ignore the presence of fuels and solvents. The water sensing cable must be positioned at the bottom of the tank and be approximately three feet in length.

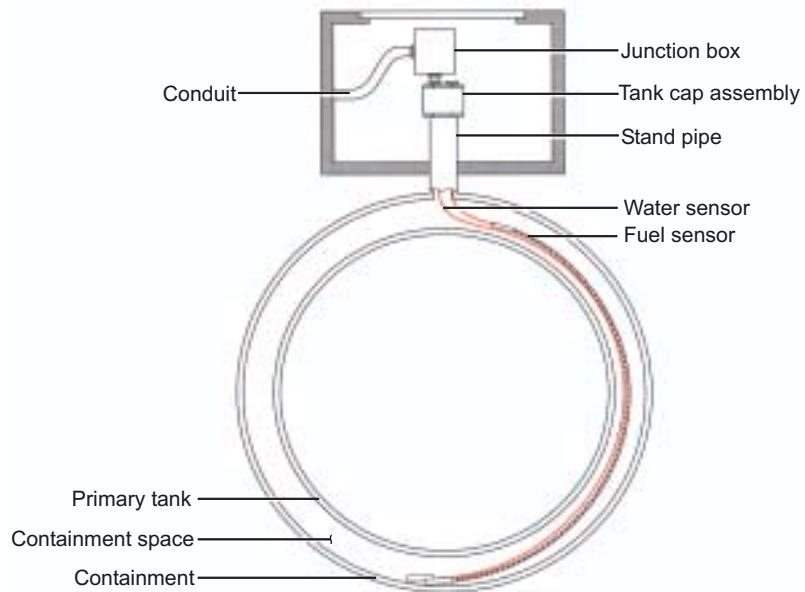

### Fiberglass reinforced plastic tank

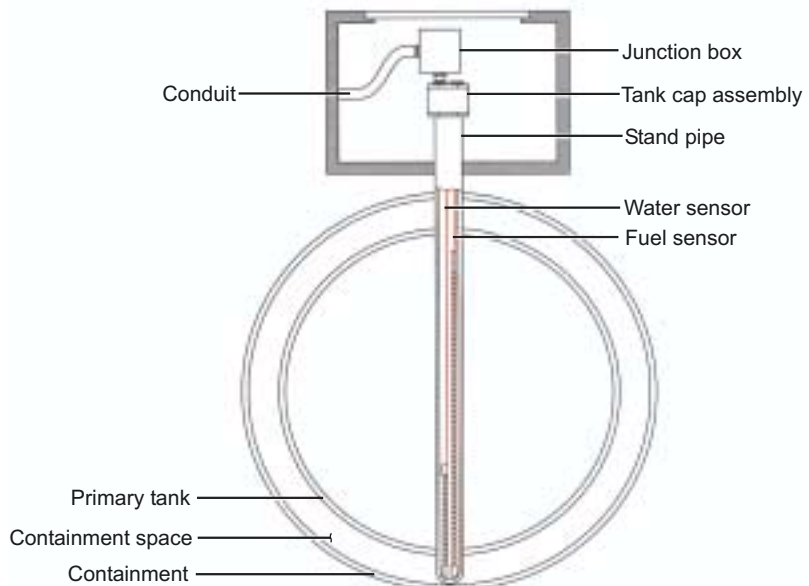

### Steel tank

For tank applications requiring only one sensing cable, a tank cap assembly with a pressure rated feedthrough fitting is recommended.

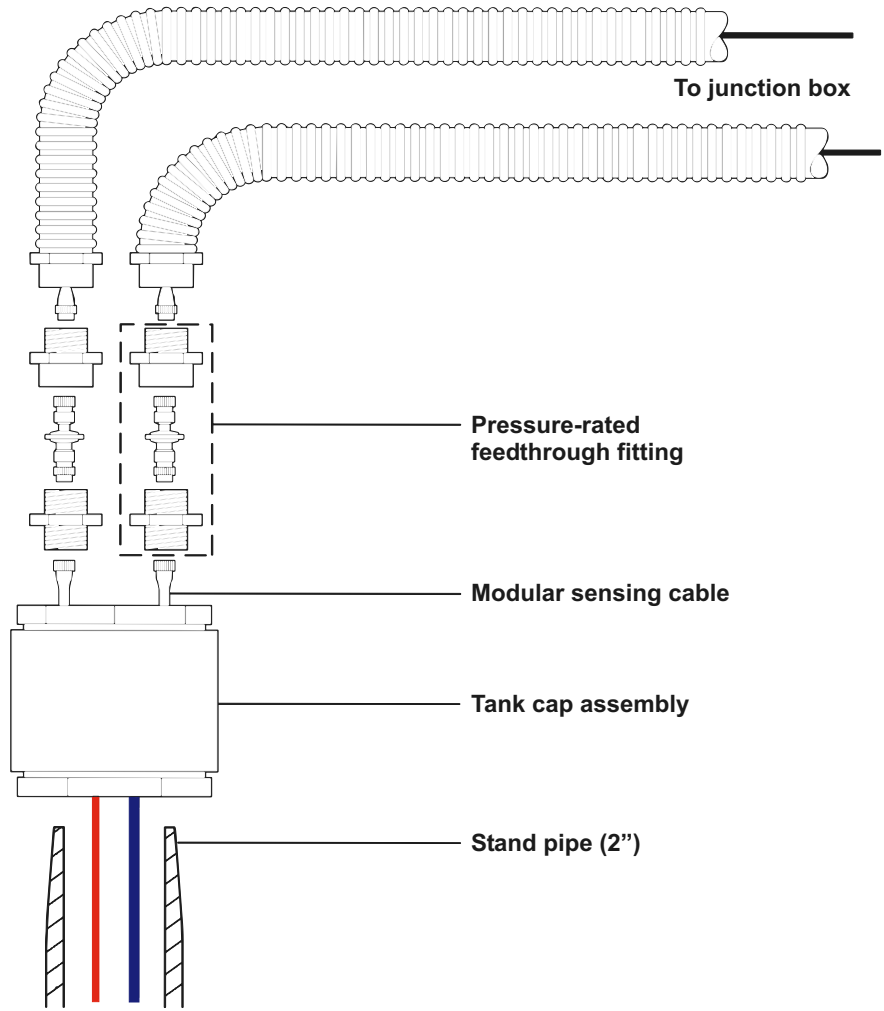

**Tank cap assembly**

## Pipe and Tank Combinations

Double-wall pipe and tank combinations may be monitored from one locating alarm module by branching off from the main pipe run to the tank.

See the next page for a detailed view of the tank cap assembly.

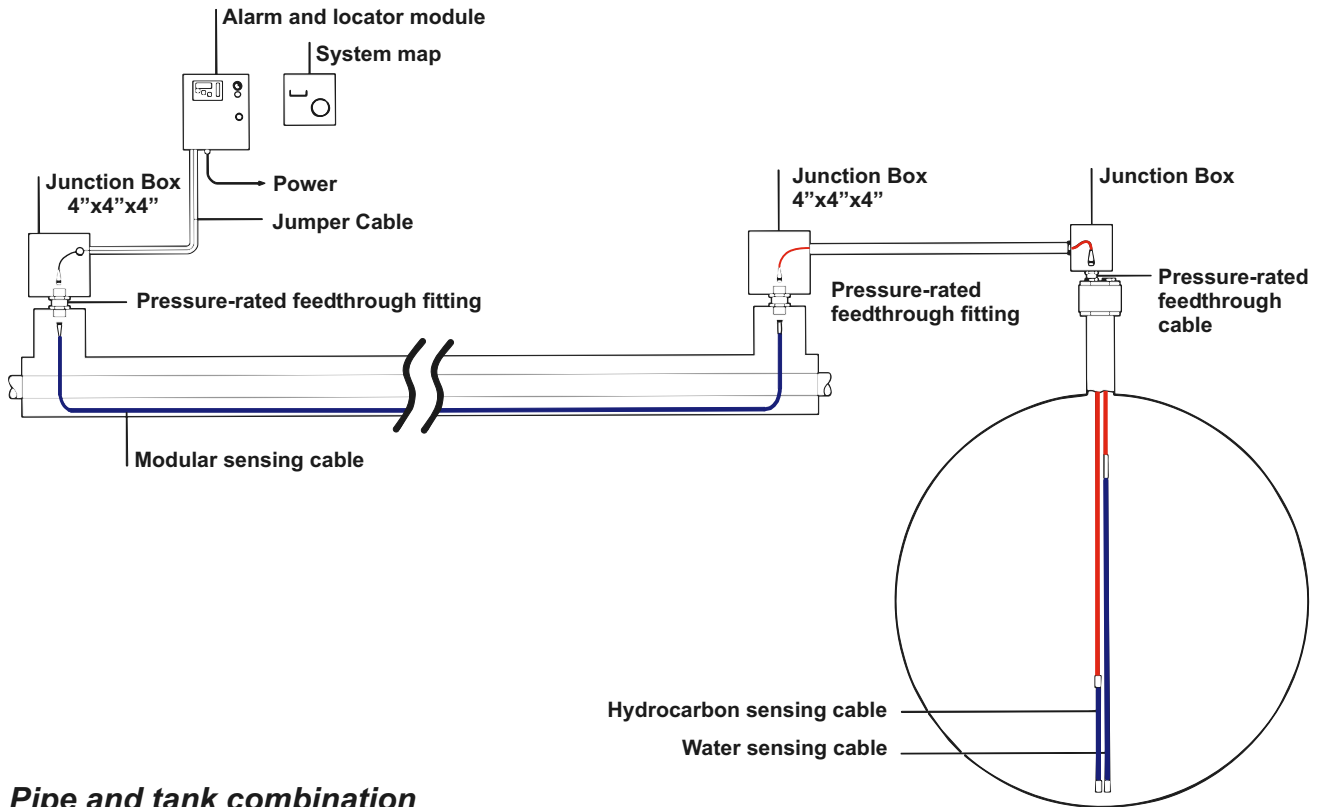

**Pipe and tank combination**

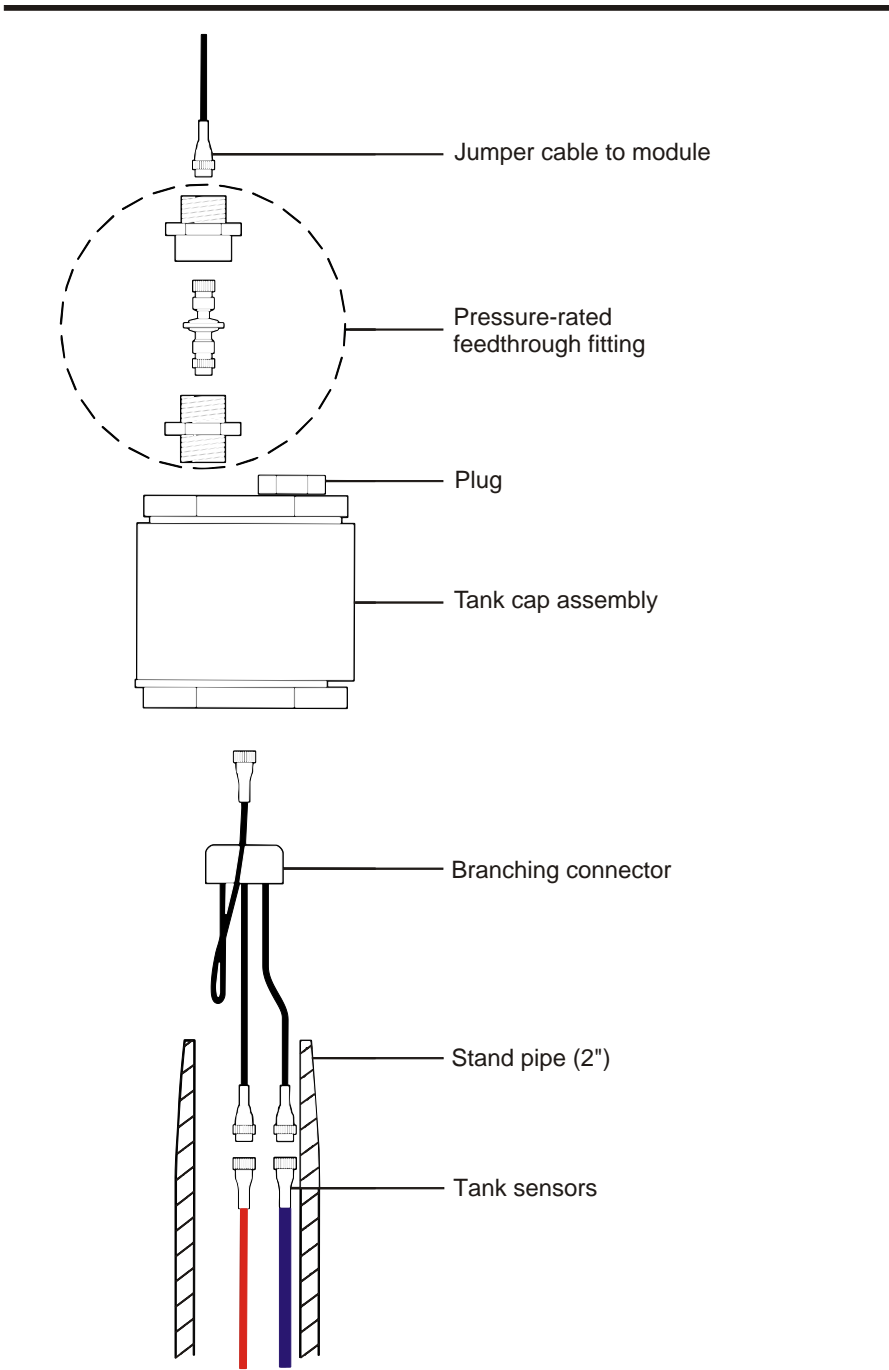

*Detail of tank cap assembly with branch connector for mounting fuel and water sensing cables in double-wall pipe and tank applications.*

## Trenches/Sumps

In trench or sump applications, the sensing cable is laid in a zigzag fashion every four to six feet, or as appropriate.

Service loops are required at every sensing cable connection.

Hold-down clips are recommended to secure the cable in place.

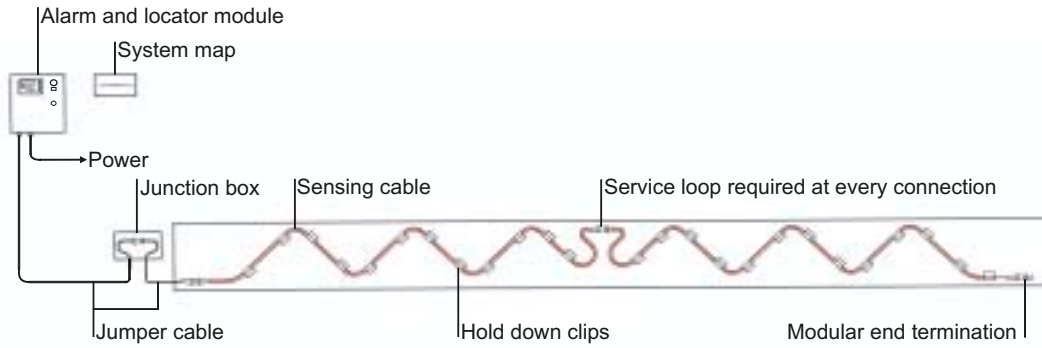

Pipes should be mounted to the side of the trench or laid on pipe racks in the trench. The sensing cable is then installed beneath the pipe racks with a minimum 0.75-inch clearance to allow removal of the cable if necessary.

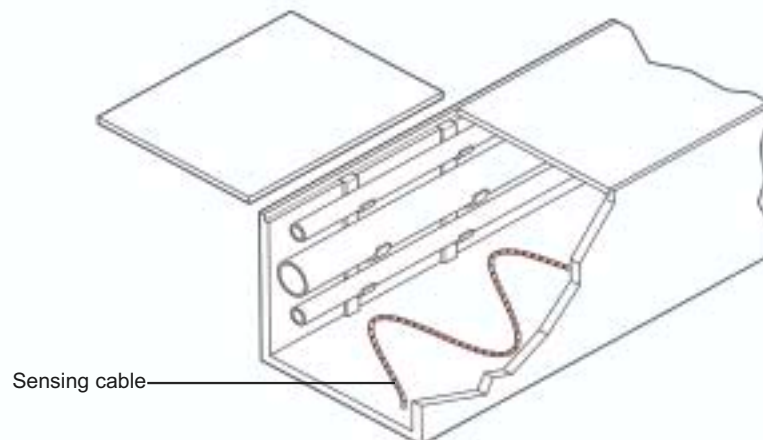
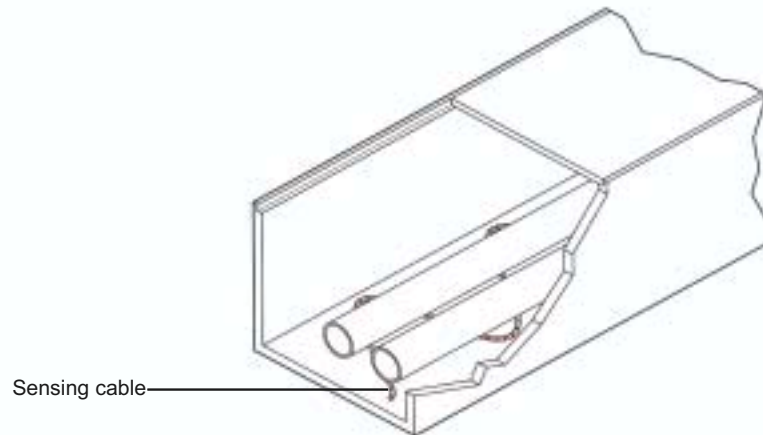

*Trenches with racked pipes*

---

***Tyco Thermal Controls, LLC***  
**Commercial & Industrial**  
**Infrastructure Division**

**300 Constitution Drive**  
**Menlo Park, CA 94025-1164**

***REPRESENTED BY:***

***California Detection Systems, Inc***  
**17155 Von Karman Avenue**  
**Suite 104**  
**Irvin, CA 92614-0906**

**TEL: (949) 223-9800**  
**FAX: (949) 223-9804**